

**QA1**  
GO DRIVE IT.



RK117K SHOWN

QA1 DROP KIT 99-06 CHEVROLET SILVERADO 1500/GMC SIERRA 1500, 2007 SILVERADO 1500 CLASSIC/SIERRA 1500 CLASSIC—INSTALLATION INSTRUCTIONS: RDK52618/52619/52620/52621

## WELCOME TO QA1!

### OUR COMMITMENT

Congratulations on your purchase of this high-quality QA1 99-06 SILVERADO 1500/SIERRA 1500, 2007 SILVERADO 1500 CLASSIC/SIERRA 1500 CLASSIC drop kit. They are engineered to the highest standards, utilizes the finest materials, and is built with exceptional craftsmanship and attention to detail.

While we understand your eagerness to start your build, please remember that your safety is our utmost priority. Always use an approved and appropriately rated jack, jack stand, or automotive lift, and take all necessary safety precautions to ensure the job is completed safely and correctly.

Before you start, read and understand all instructions thoroughly. With hand tools and essential equipment, you can do the main assembly and setup of your new drop kit in your home garage, but if you feel unsure of your abilities during the assembly or installation and need some help or have any uncertainties, please seek the assistance of a qualified mechanic or automotive repair shop.

If you have any product questions or need guidance, please don't hesitate to call and speak with QA1 technical support at 952-985-5675.

Remember, we're here to support you every step of the way and are committed to ensuring your assembly and installation process is successful and enjoyable. We wish you all the best!

### BEFORE INSTALLATION

Before you begin the QA1 99-06 SILVERADO 1500/SIERRA 1500, 2007 SILVERADO 1500 CLASSIC/SIERRA 1500 CLASSIC drop kit installation, read and understand these instructions carefully. If instructions are not correctly followed, personal injury, equipment, or product damage can result.

Products that have been installed are not eligible for returns. To prevent mistakes, thoroughly read these instructions before you start the drop kit assembly procedure.

Check your order as soon as possible upon delivery. QA1 has provided parts list tables and images, as shown on pages 4 through 7. Compare your order's contents against the tables. Call your authorized dealer immediately if you discover anything missing from your order.

This kit requires no welding to assemble and install.

It is important to wear the appropriate personal protective equipment (PPE). However, the responsibility does not end there. Follow the manufacturer's instructions for safe use when working with power tools, and be cautious and responsible in your work. Make sure to ventilate combustible vapors and remove any nearby flammable materials.

## ABOUT THIS MANUAL

### PURPOSE

These instructions outline the installation of the QA1 drop kit. This system is designed to work with the factory leaf springs and fits the following vehicles:

- 1999-2006 Chevrolet Silverado 1500 w/Coil Spring Front Suspension
- 2007 Chevrolet Silverado 1500 w/Classic Coil Spring Front Suspension
- 1999-2006 GMC Sierra 1500 w/Coil Spring Front Suspension
- 2007 GMC Sierra 1500 w/Classic Coil Spring Front Suspension

### ITS CONTENTS

The information that follows is described in this instruction set:

- Required tools and supplies.
- Safety, hazard, and warning rules.
- Product overview and included parts.
- Installation and the setup procedures required for use.

Pages with images will have paragraphs and sentences with callout numbers that refer to their respective images, steps, and parts.

Procedures, once described in the text, are generally not repeated. When it is necessary to refer to another procedure, the page and step reference will be given.

### REQUIRED TOOLS AND SUPPLIES

- Floor Jack
- Jack Stands
- SAE and Metric Wrench Set
- SAE and Metric Socket Set
- Torque Wrench (lb-ft)

### SAFETY FIRST

- Work on your vehicle in an appropriate location.
- Park your car on a level surface.
- Use wheel chocks to prevent vehicle roll.
- Check your owner's manual for the correct jack lift points.
- Always support your vehicle with jack stands.
- Wear personal protection like safety glasses, gloves, and a fine particle respirator mask.
- Never use compressed air to clean brake or metal grinding dust from the brake, suspension components, frame, or rear axle housing.
- Grind metal only in a well-ventilated area, and wear a respirator until the dust has settled and the work area air has been cleared.
- Dispose of damaged or old parts in accordance with local laws. Do not throw any hazardous waste in the trash.
- Follow the manufacturer's instructions for safe use when working with power tools, and be cautious and responsible in your work.

**CONTENTS**

**QA1 DROP KIT** ..... 4-20

**PARTS LIST** ..... 4

**VEHICLE PREPARATION** ..... 8

**DISASSEMBLY** ..... 9-13

**REAR LEAF SPRING SHACKLE** ..... 9

**FRONT LEAF SPRING REMOVAL** ..... 12

**FRONT LEAF SPRING MOUNT REMOVAL** ..... 13

**ASSEMBLY** ..... 14-23

**RK116K FRONT LEAF SPRING MOUNT** ..... 14

**RK117K FRONT LEAF SPRING MOUNT** ..... 16

**BUMP STOP** ..... 18

**LEAF SPRING, FRONT** ..... 19

**REAR LEAF SPRING SHACKLE** ..... 21

**ADJUSTMENT, PINION ANGLE** ..... 24

**WARRANTY** ..... 25

99-06 SILVERADO 1500/SIERRA 1500, 2007 SILVERADO 1500 CLASSIC/SIERRA 1500 CLASSIC DROP KIT RK116K w/INSTALL KIT 7039-439 (Customer will receive this kit for short bed trucks)

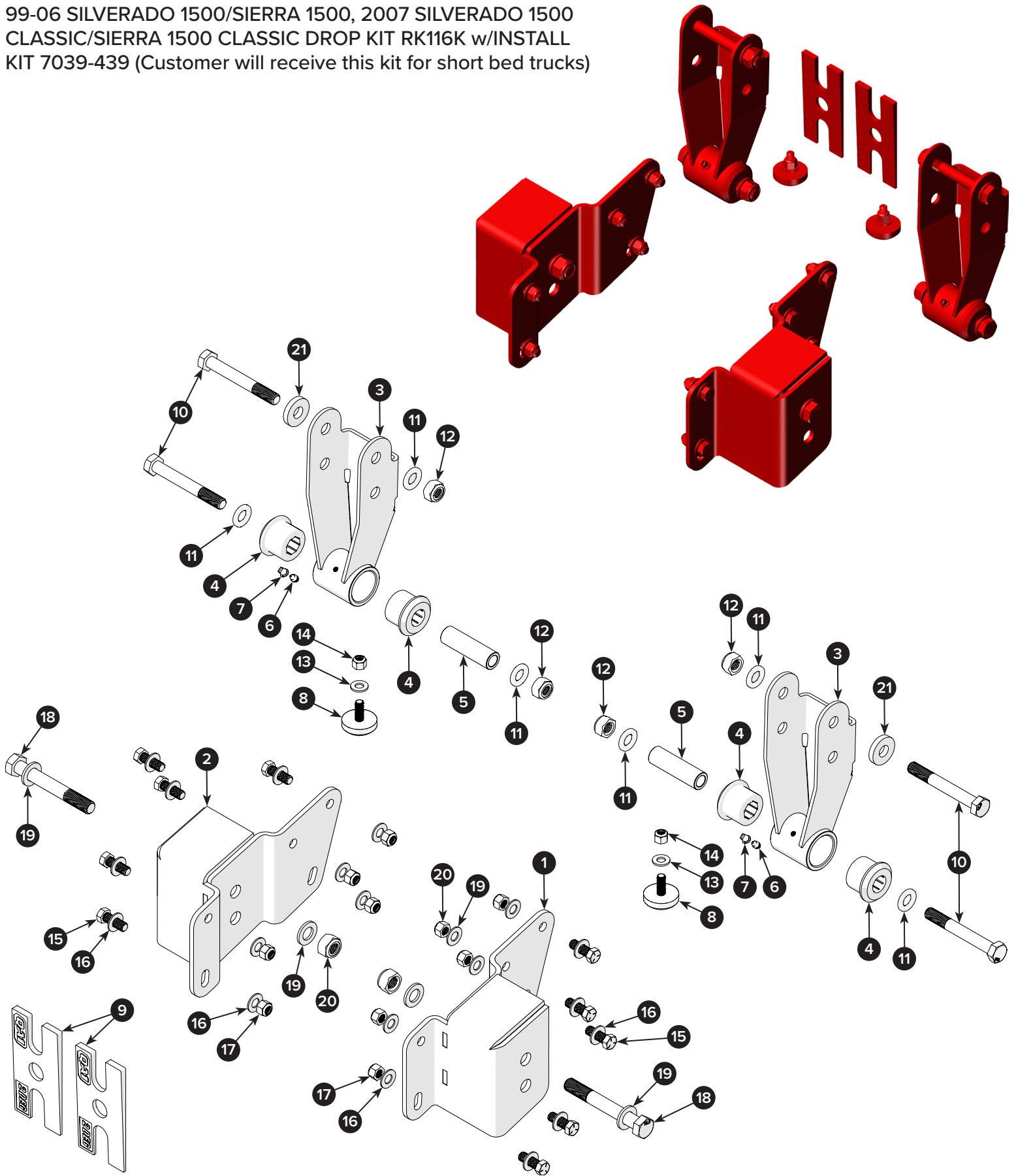

**1999-2007 SILVERADO/SIERRA, 2WD SHORT BED, RK116K**

POSITION	PART #	DESCRIPTION	QTY	TORQUE SPECIFICATION
1	9637-935	WELDMENT, LEAF SPRING MOUNT, LH	1	—
2	9637-936	WELDMENT, LEAF SPRING MOUNT, RH	1	—
3	9637-687	WELDMENT, SPRING SHACKLE	2	—
4	9032-439	BUSHING, POLY 2-PIECE, BLACK	4	—
5	9033-520	SLEEVE, .875" OD X .563" ID X 3.00" L	2	—
6	9023-119	FITTING, ZERK 1/4-28, STRAIGHT	2	—
7	9023-116	CAP, GREASE ZERK	2	—
8	9047-114	BUMP STOP, FLAT 1.625" OD X .688" TALL	2	—
9	9004-221	PINION SHIM, 2 DEG, 2.5" LEAF SPRING	2	—

**1999-2007 SILVERADO/SIERRA DROP KIT INSTALL KIT 7039-439**

POSITION	PART #	DESCRIPTION	QTY	TORQUE SPECIFICATION
10	N/A	BOLT, HEX M14-2.0 X 110mm	4	—
11	9005-229	WASHER, FLAT M14	6	—
12	9014-578	NUT, NYLOCK M14-2.0	4	70 lb-ft
13	9005-239	WASHER, SPLIT LOCK 3/8"	2	—
14	9014-333	NUT, HEX 3/8-16	2	10 lb-ft
15	N/A	BOLT, HEX 7/16-14 X 1.25"	10	—
16	9005-243	WASHER, FLAT 7/16" SAE	20	—
17	N/A	NUT, NYLOCK 7/16-14	10	49 lb-ft
18	9012-380	BOLT, M16-2.0 X 115mm	2	110 lb-ft
19	9005-234	WASHER, FLAT M16	4	—
20	N/A	NUT, NYLOCK, M16-2.0	2	—
21	N/A	WASHER, FLAT FENDER M14	2	—

**Note:** The part positions listed above will be called out in this installation manual as a visual reference to their respective positions during the installation procedure. Refer to these pages during the installation. Count and compare all parts and fasteners to the list above. If parts are missing, contact QA1 at sales@qa1.net.



99-06 SILVERADO 1500/SIERRA 1500, 2007 SILVERADO 1500 CLASSIC/SIERRA 1500 CLASSIC DROP KIT RK116K w/INSTALL KIT 7039-439 (Customer will receive this kit for long bed trucks)

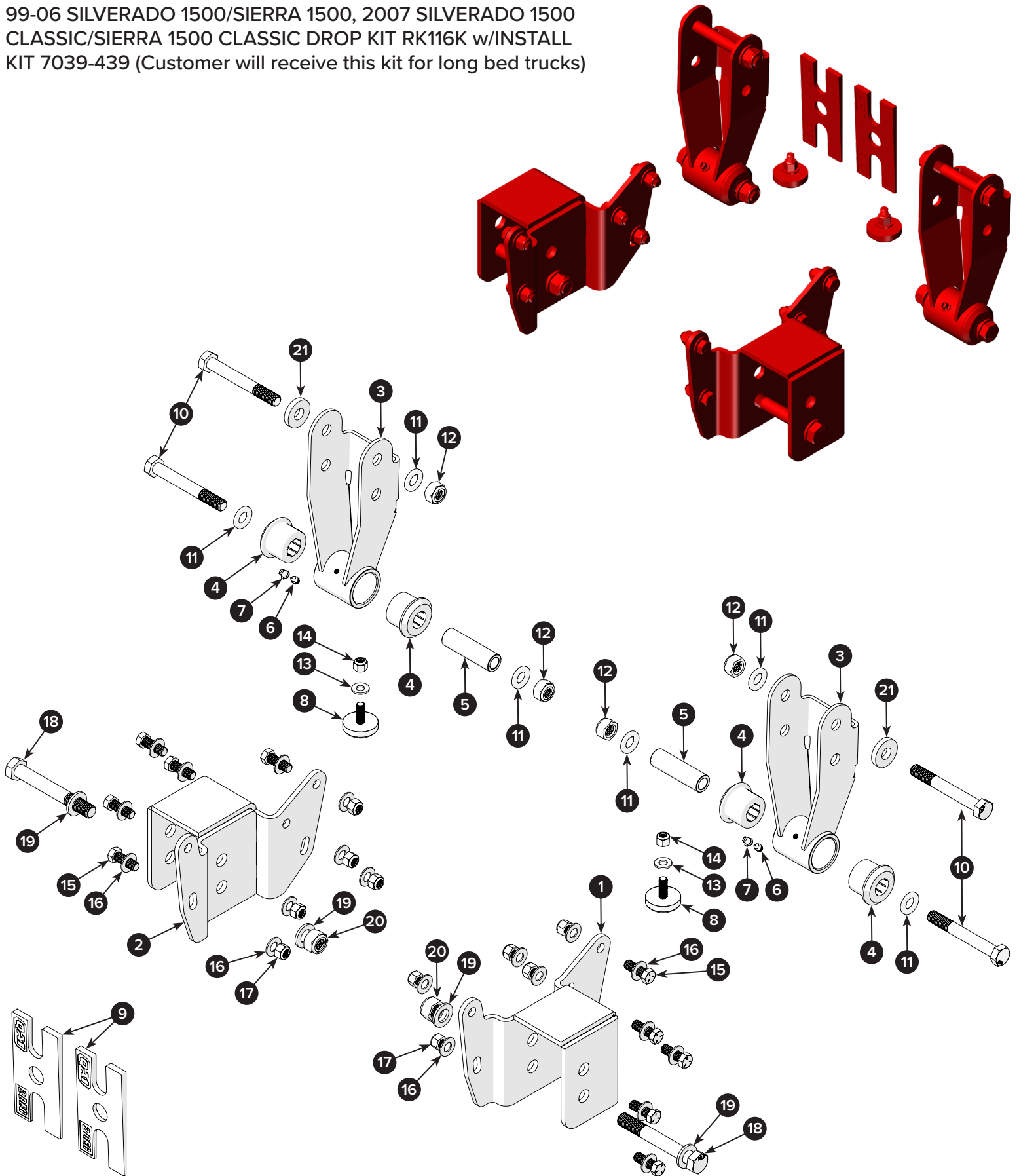

**1999-2007 SILVERADO/SIERRA, 2WD LONG BED, RK117K**

POSITION	PART #	DESCRIPTION	QTY	TORQUE SPECIFICATION
1	9637-933	WELDMENT, LEAF SPRING MOUNT, LH	1	—
2	9637-934	WELDMENT, LEAF SPRING MOUNT, RH	1	—
3	9637-687	WELDMENT, SPRING SHACKLE	2	—
4	9032-439	BUSHING, POLY 2-PIECE, BLACK	4	—
5	9033-520	SLEEVE, .875" OD X .563" ID X 3.00" L	2	—
6	9023-119	FITTING, ZERK 1/4-28, STRAIGHT	2	—
7	9023-116	CAP, GREASE ZERK	2	—
8	9047-114	BUMP STOP, FLAT 1.625" OD X .688" TALL	2	—
9	9004-221	PINION SHIM, 2 DEG, 2.5" LEAF SPRING	2	—

**1999-2007 SILVERADO/SIERRA DROP KIT INSTALL KIT 7039-439**

POSITION	PART #	DESCRIPTION	QTY	TORQUE SPECIFICATION
10	N/A	BOLT, HEX M14-2.0 X 110 mm	4	—
11	9005-229	WASHER, FLAT M14	6	—
12	9014-578	NUT, NYLOCK M14-2.0	4	70 lb-ft
13	9005-239	WASHER, SPLIT LOCK 3/8"	2	—
14	9014-333	NUT, HEX 3/8-16	2	10 lb-ft
15	N/A	BOLT, HEX 7/16-14 X 1.25"	10	—
16	9005-243	WASHER, FLAT 7/16" SAE	20	—
17	N/A	NUT, NYLOCK 7/16-14	10	49 lb-ft
18	9012-380	BOLT, M16-2.0 X 115 mm	2	110 lb-ft
19	9005-234	WASHER, FLAT M16	4	—
20	N/A	NUT, NYLOCK, M16-2.0	2	—
21	N/A	WASHER, FLAT FENDER M14	2	—

**Note:** The part positions listed above will be called out in this installation manual as a visual reference to their respective positions during the installation procedure. Refer to these pages during the installation. Count and compare all parts and fasteners to the list above. If parts are missing, contact QA1 at sales@qa1.net.



**Installer's Note:** This instruction set shows only the frame and chassis of the 99-06 Silverado/Sierra pickup truck. The body has been removed for visual clarity.

**1** Use a floor jack and lift the vehicle at its designated lift points.

To access the front and rear suspension, set the vehicle on jack stands (shown) or a hydraulic lift under the frame as shown.

**Note:** Jack stands must be level and evenly positioned for safe vehicle load. Adjust the jack stands as necessary.

In this image, jack stands are also shown under the rear differential.

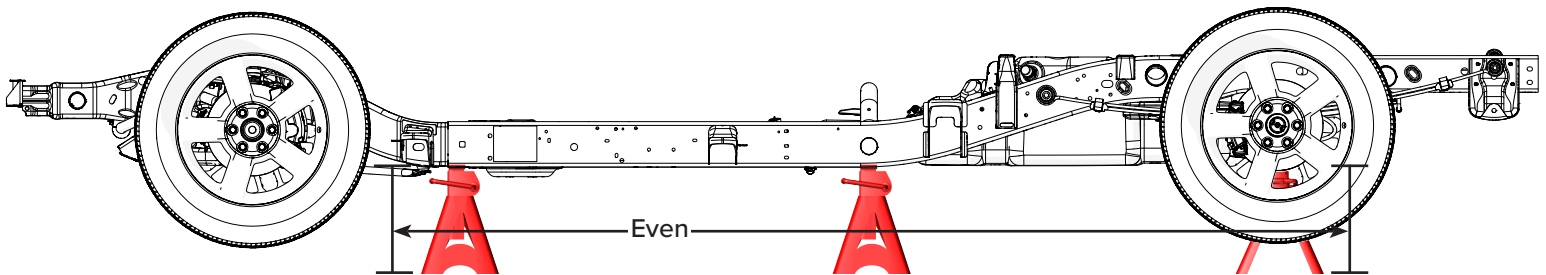
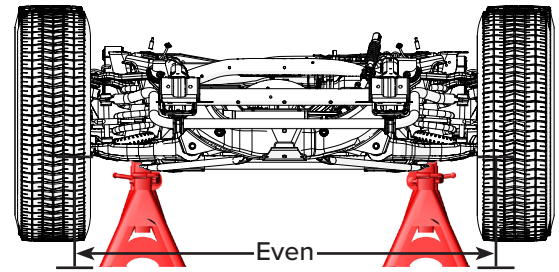

**Installer's Note:** These instructions begin on the rear driver's side of the vehicle.

The procedure to replace the leaf spring perches on the passenger side is the same as that for the driver's side.

**2** First, remove the lug nuts and wheels from both the left and right sides of the rear of the vehicle.

Then, remove both rear shocks (not shown) from the shock mounts on the axle.

Discard the shocks, as they will not be reused.

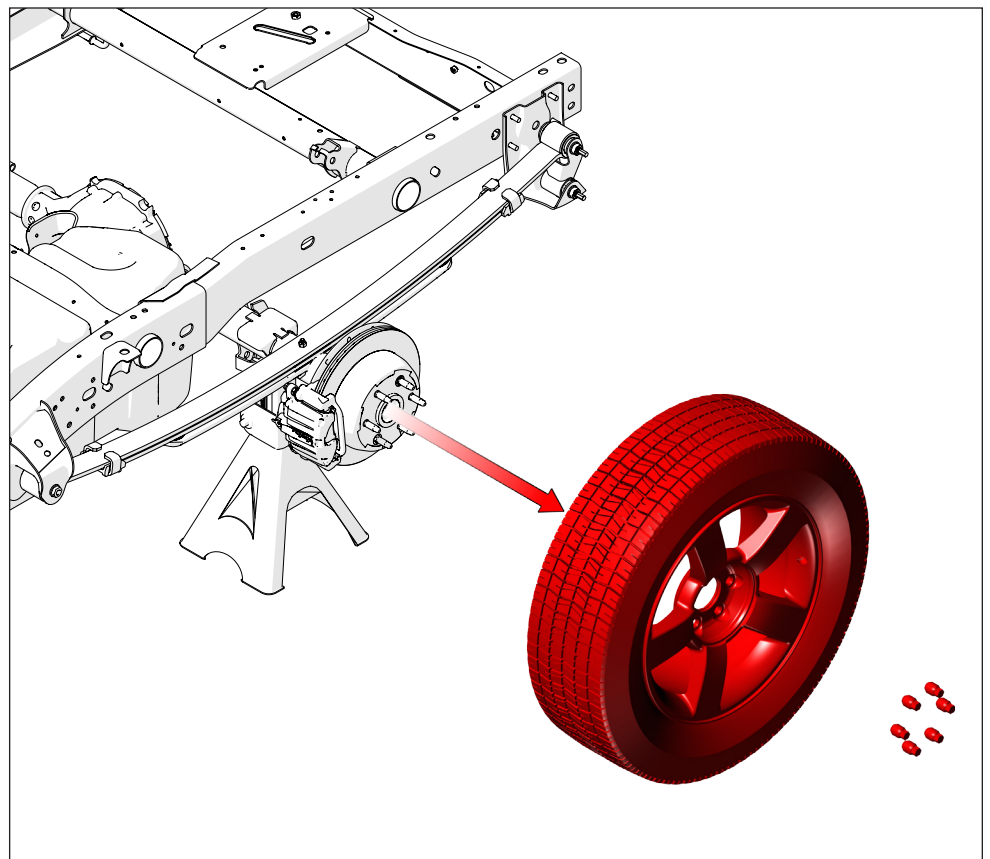

**Installer's Note:** The new hardware included in the drop kit replaces the factory hardware, so there is no need to keep the old factory hardware that was removed during the installation of the drop kit.

- 3** First, loosen and remove the nut (A) and washer (B) from the lower side of the rear spring shackle.

Discard the nut and washer, as they will not be reused.

Next, loosen, but do not remove, the nut (A) from the upper side of the spring shackle.

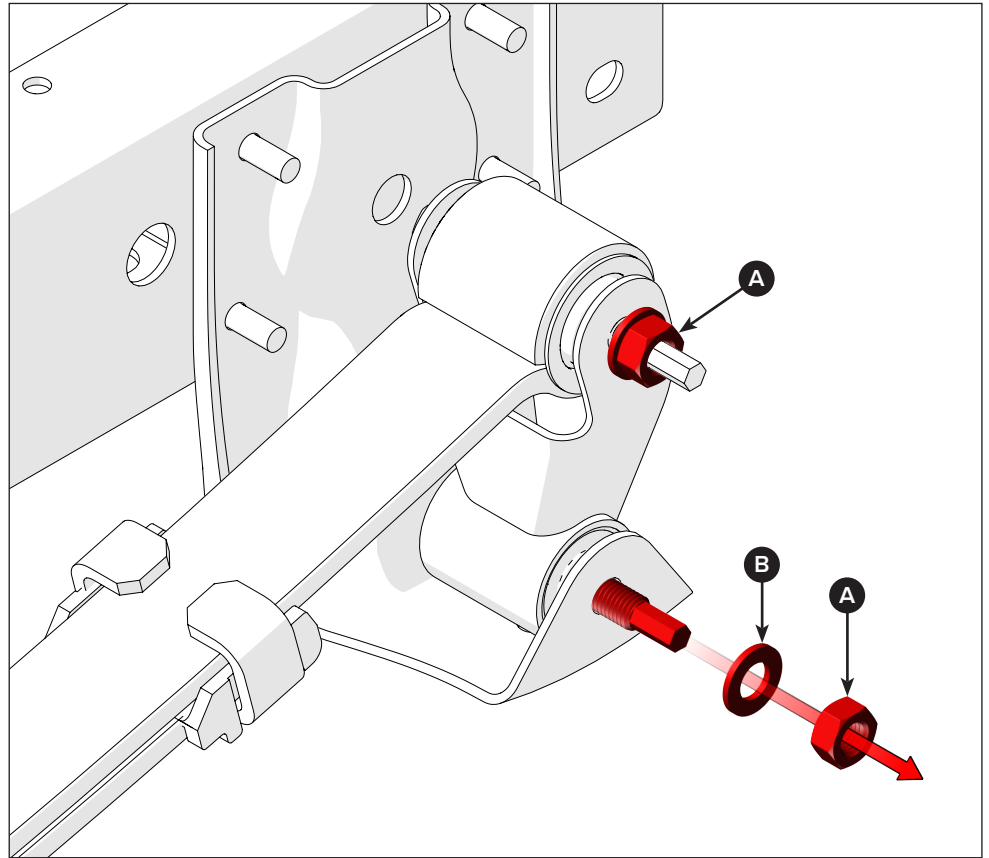

- 4** Drive out the lower shackle bolt (C) and discard it, as it will not be reused.

In some instances, the bolt requires concentrated heat to help loosen all rust.

**Note:** If the bolt is trapped between the back of the spring perch and a frame member, remove the bolt as far as it will go, then cut it.

Repeat the bolt removal process and cut again if necessary. Continue until the bolt is fully removed.

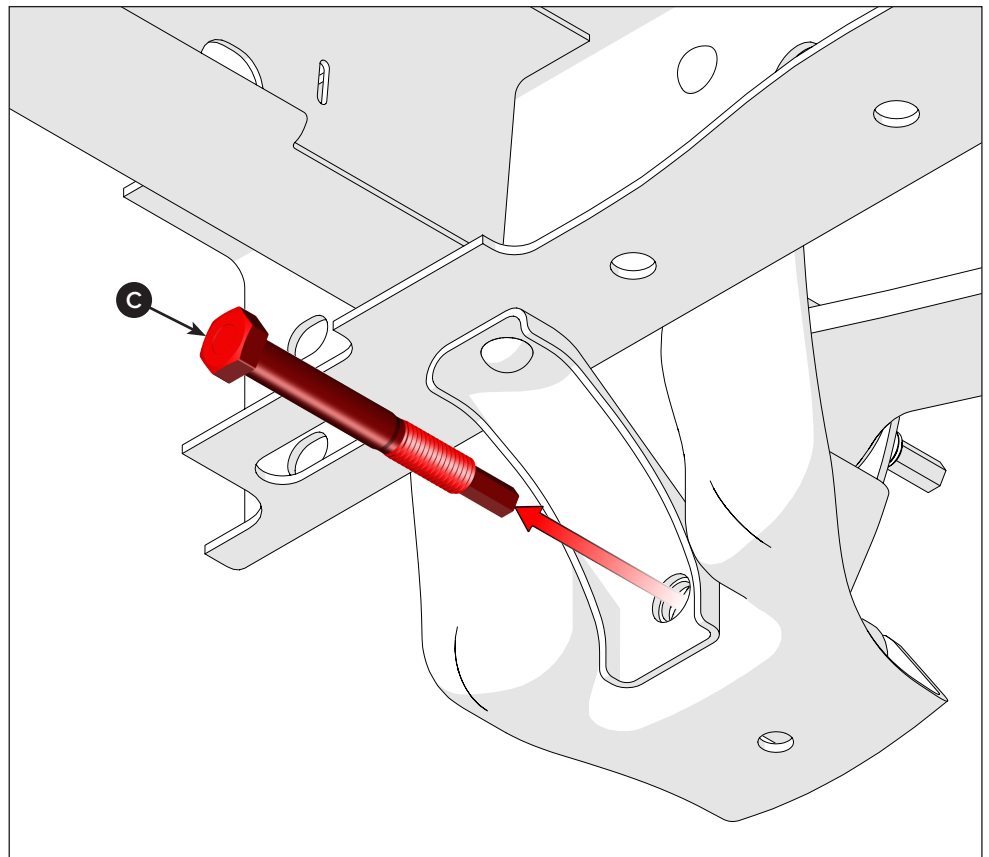

**Installer's Note:** This image does not show the body or truck bed. The leaf spring and shackle must be pushed up until it contacts the bottom of the bed.

To gain full and easy access to the rear and front spring mounts, remove the bed with the aid of additional helpers.

- 5 With the shackle's bottom bolt removed, push the spring and shackle upward until the upper shackle bolt head clears the top of the frame.

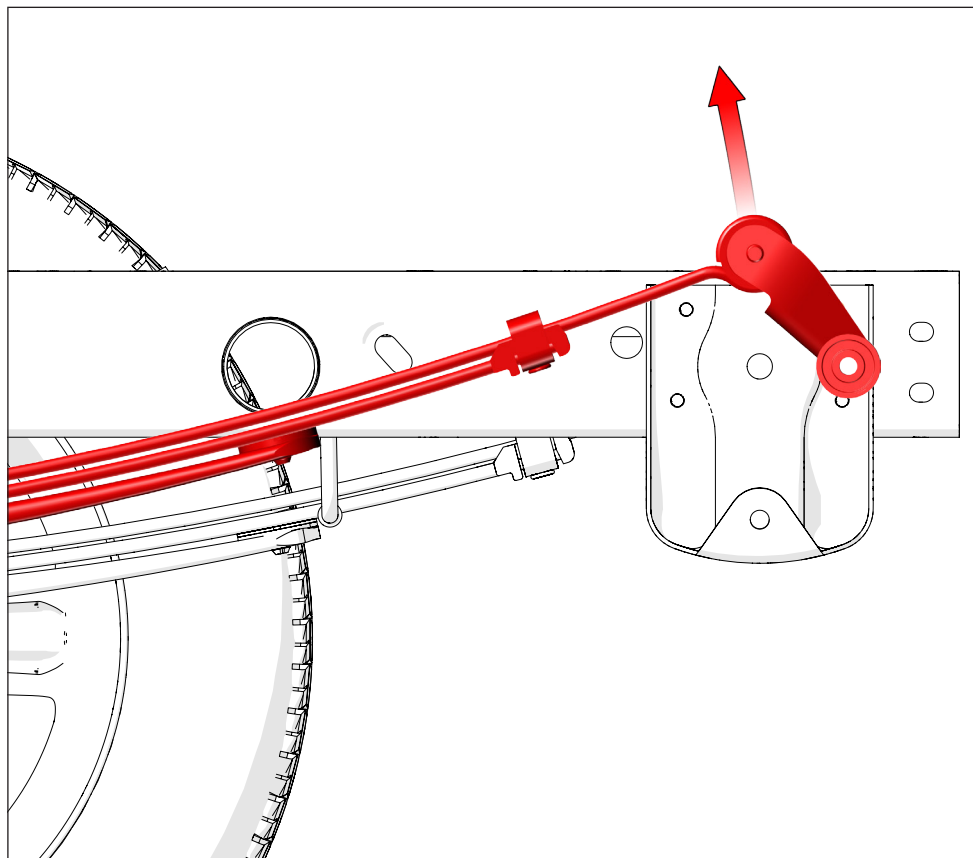

- 6 Now, remove the nut (A) and washer (B) from the upper shackle mount.

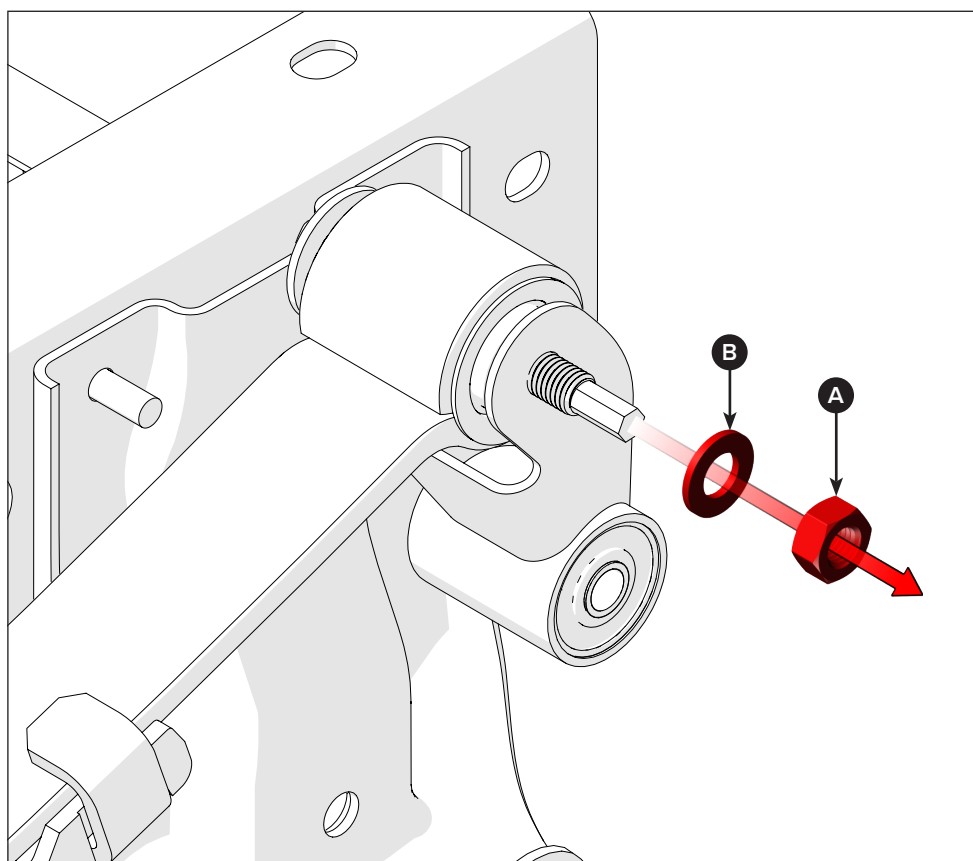

- 7** Drive out the upper shackle bolt (C) and discard it, as it will not be reused.

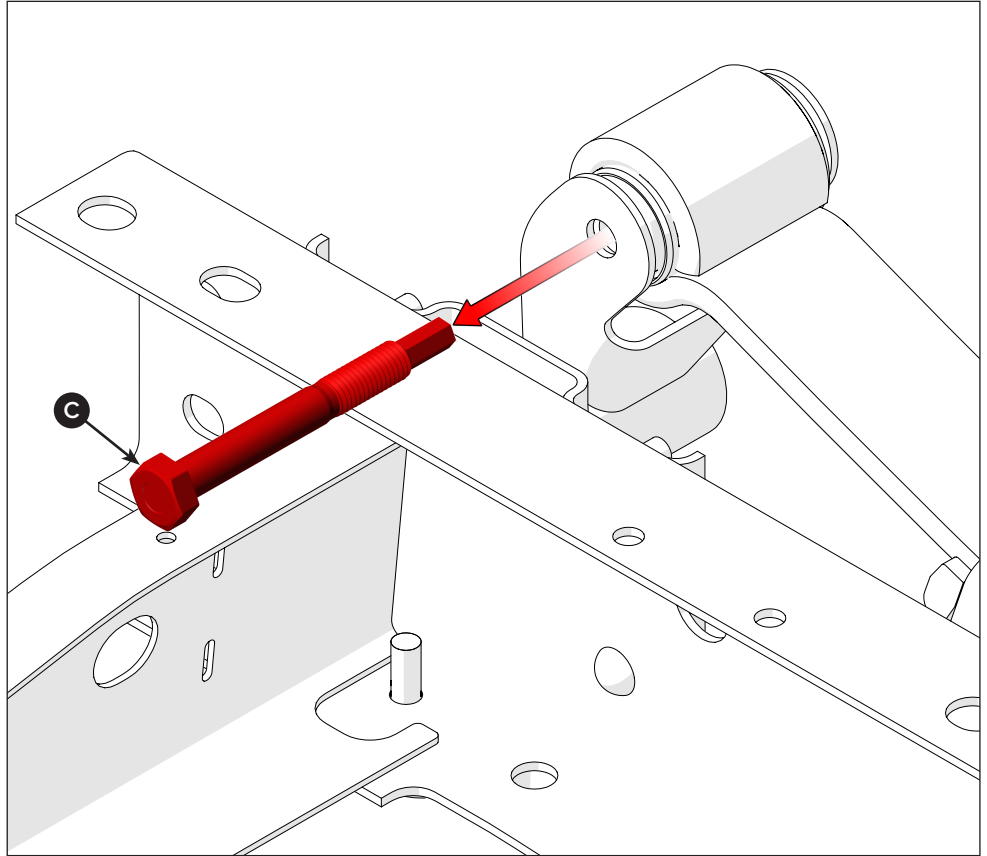

- 8** Once the shackle bolt is removed, pull the factory spring shackle (D) away from the spring eyelet. Discard the shackle, as it will not be reused.

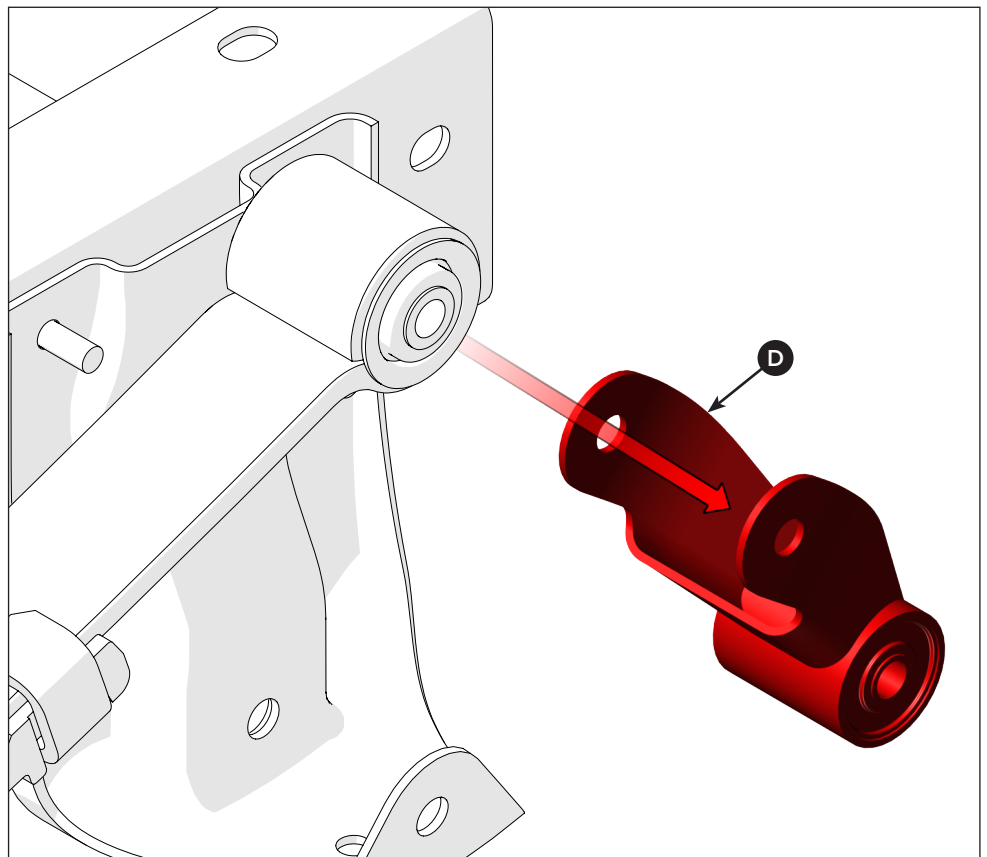

9

Remove the nut (E), washer (F), and bolt (G) from the front spring mount. Discard these fasteners, as they will not be reused.

Repeat steps 2 through 9 to disconnect the right side leaf spring from the frame. Both sides must be free from the frame to continue.

**Note:** The factory bolt is trapped between the frame and the fuel tank. To remove these bolts, the fuel tank can be removed, or the bolt cut with the tank in place.

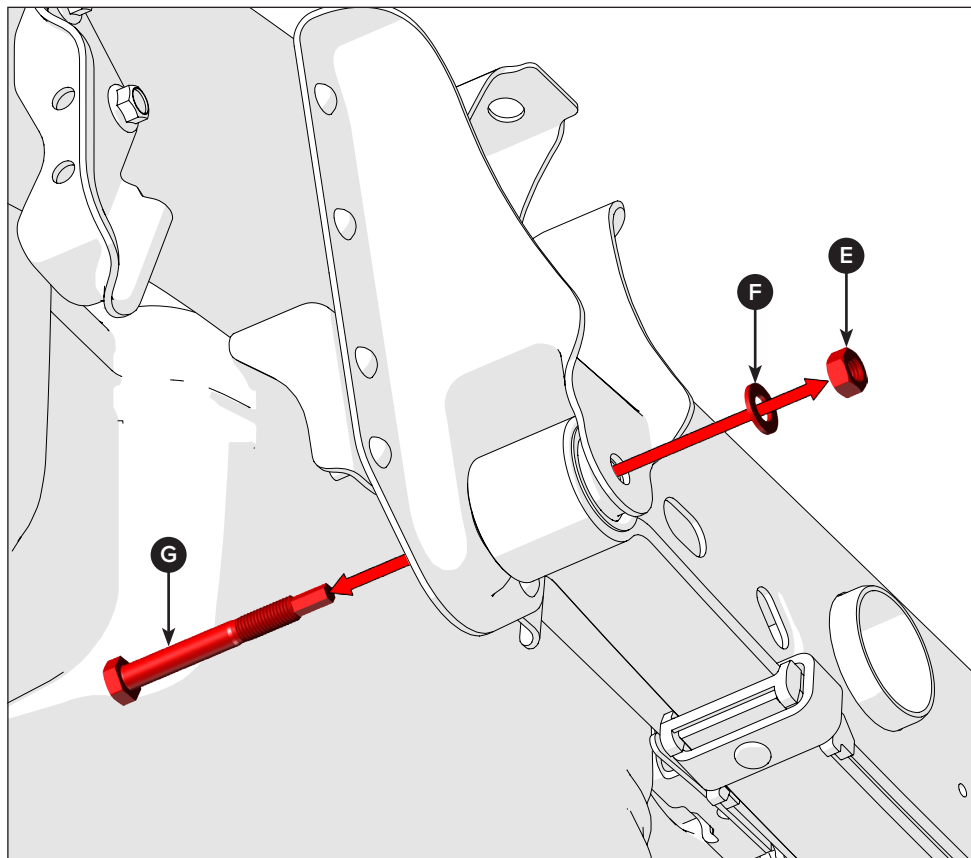

**Installer's Note:** Although this step is not required, it will create additional space to access the front spring mounts in step 11.

10

Place a floor jack under the center housing of the rear axle.

Remove the jack stands from under the axle.

With the left and right leaf springs disconnected from the frame, use the floor jack to lower the rear axle and spring assembly.

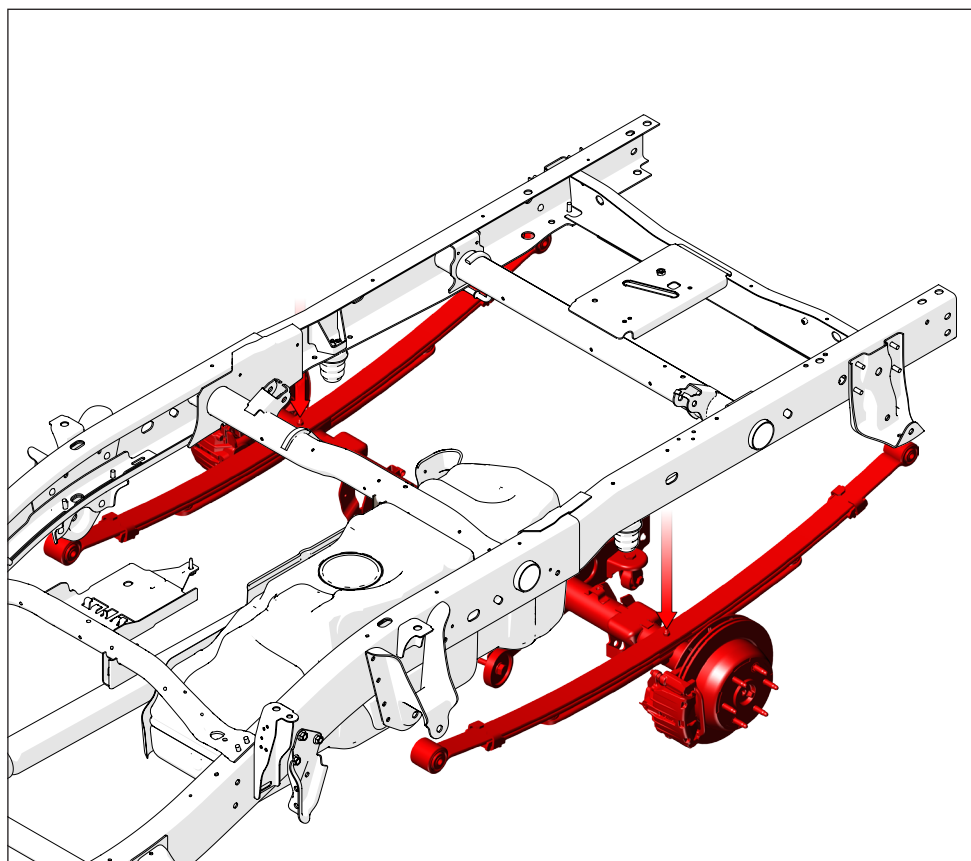

**Installer's Note:** Although this step is not required, the fuel tank can be removed from the vehicle to prevent damage to the tank.

The steps that follow show the fuel tank still in place on the vehicle.

- 11** To prevent damage to the parking brake cable, first disconnect the cable from the left side frame rail. Then, move the cable out of the way to avoid damage during rivet removal.

The rivets can be removed with a drill and bit, or a cut-off tool and air chisel.

**Drill method:** Use a cut-off tool to cut cross slots into each rivet head, then use a drill and correct bit to drill out the rivets (H) from the front spring bracket.

**Air chisel method:** Use a cut-off tool to cut cross slots into each rivet head, then use a cold chisel bit to cut off the rivet heads (H) from the front spring bracket. Use a pointed air chisel bit to drive the rivet body from the frame.

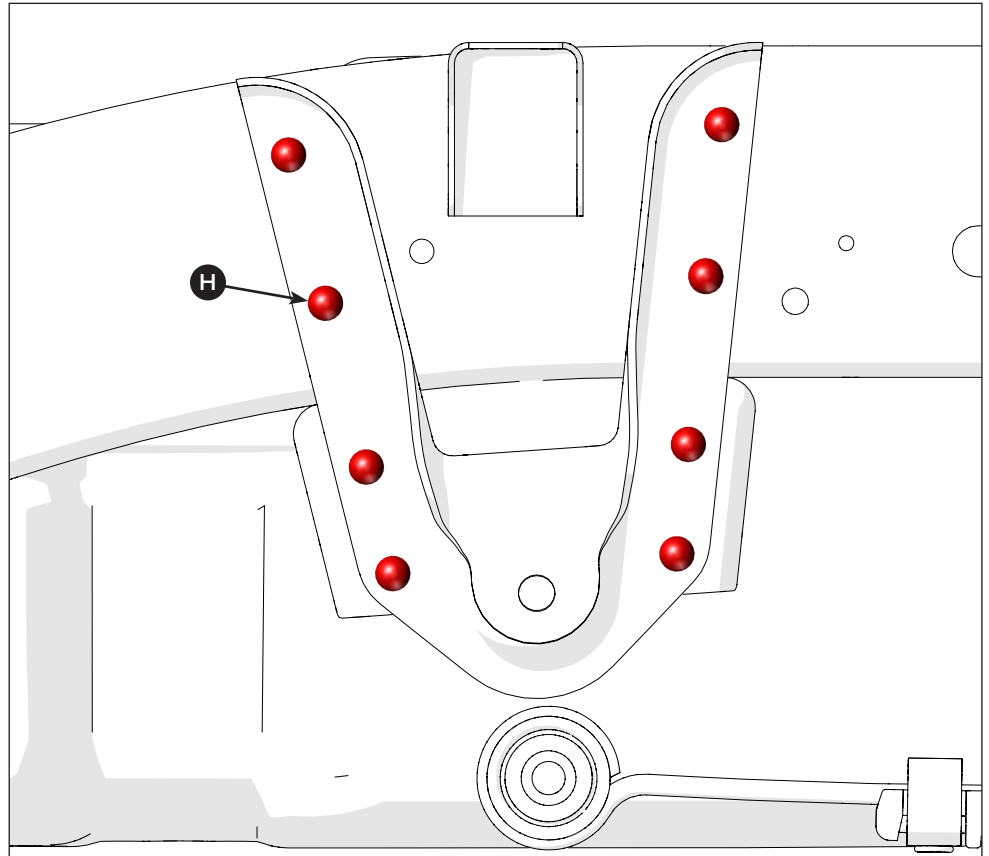

- 12** Remove and discard the front spring mount (I) and all removed rivets, as none of these parts will be reused.

**Note:** The lower front spring mount bracket (J) will no longer be used. It can be removed or left in place. To remove it, the bottom rivets (not shown) must be removed, similar to the procedure in step 11.

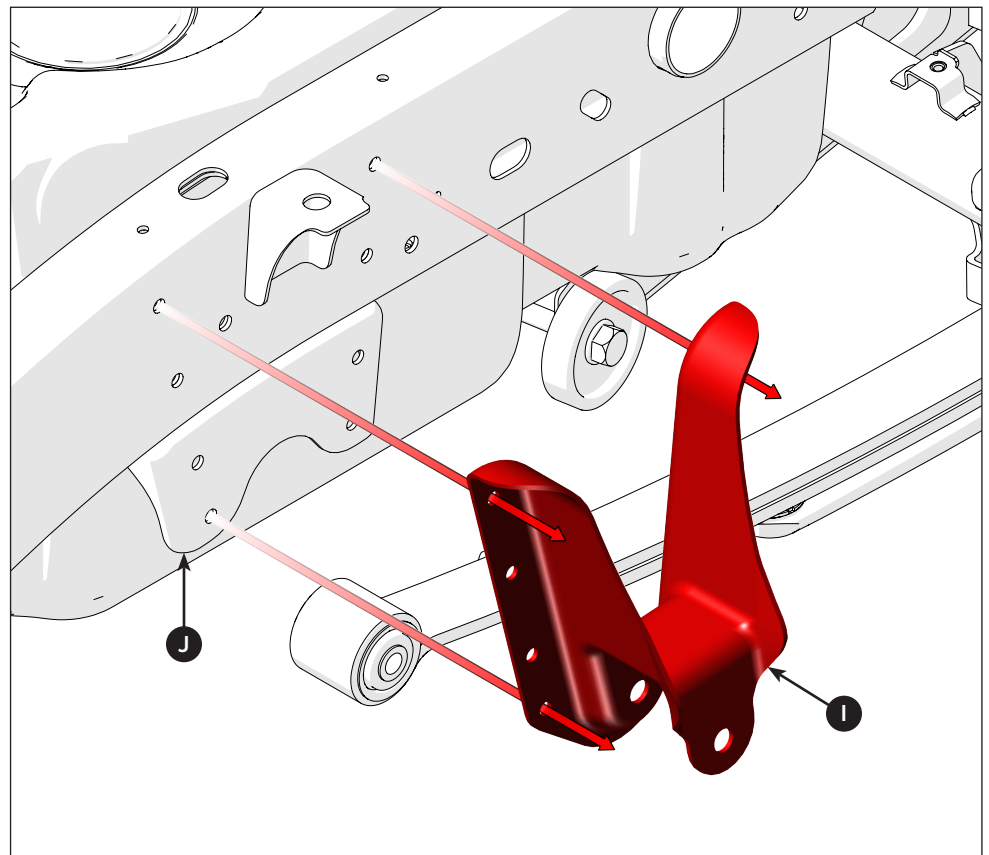

**Installer's note:** Pages 14 and 15 show the front spring mount installation procedure for a short bed with drop kit RK116K.

**13**

Use a 15/32" drill bit and a drill to clean up and open the four rivet holes that are circled in red.

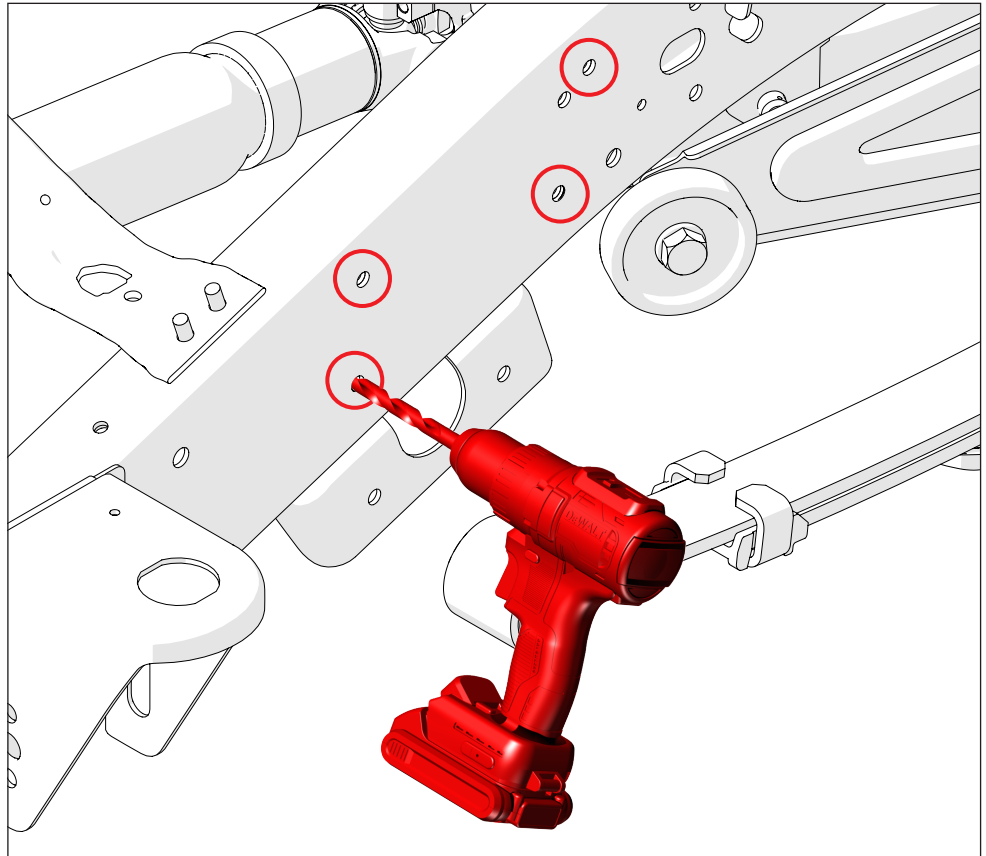

**14**

Attach the front spring mount (1) to the left side of the frame.

Use four bolts (15), eight flat washers (16), and four Nylock nuts (17).

Snug the fasteners for now, as they will be torqued to specification during step 16.

**Note:** Four of the flat washers and the Nylock nuts attach from the inner frame channel.

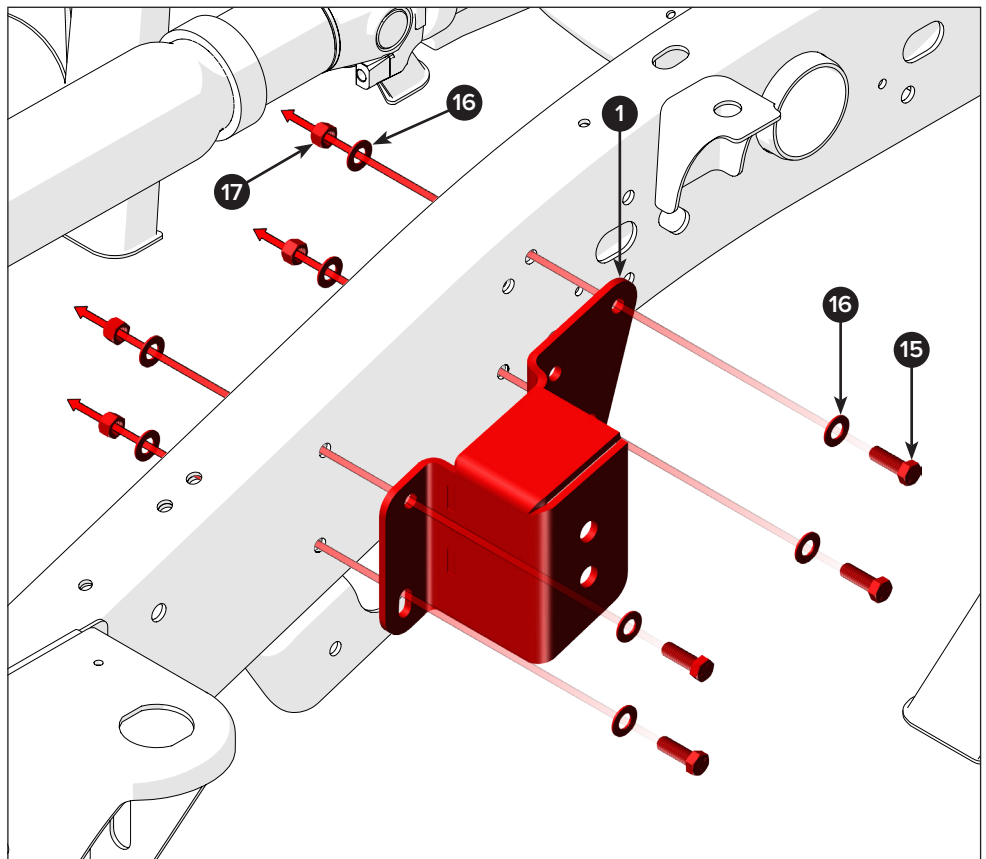

- 15** Drill through the fifth hole in the spring mount with the 15/32" bit.

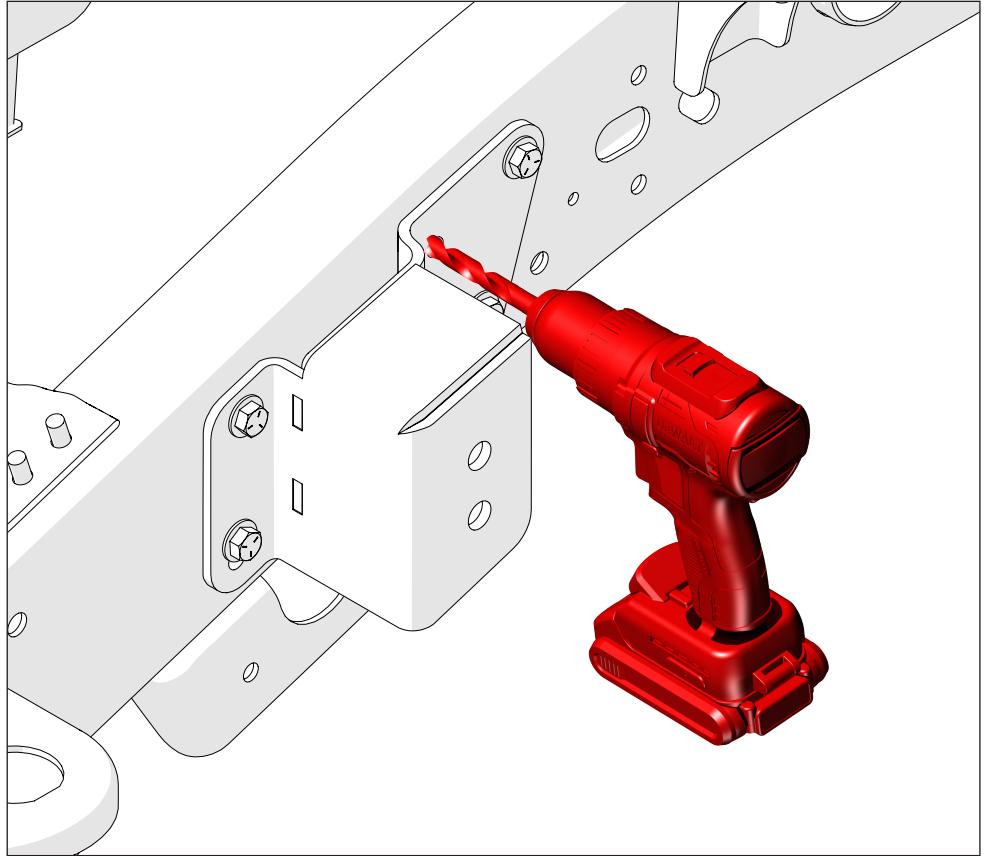

- 16** Use one bolt (15), two flat washers (16), and one Nylock nut (17) to complete the spring mount attachment.
- Torque all front spring mount hardware to 49 lb-ft.
- Repeat steps 14 through 16 to attach the right-side spring mount (2).

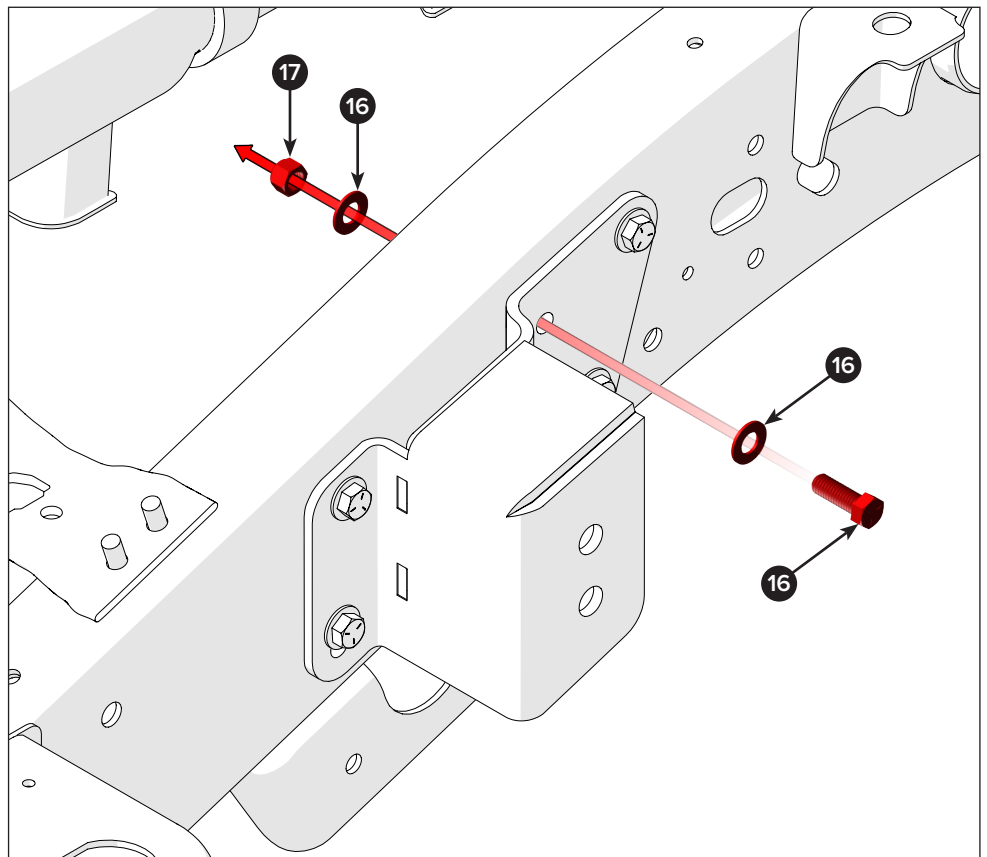

**Installer's note:** Pages 16 and 17 show the front spring mount installation procedure for a long bed with drop kit RK117K.

17

First, use a 15/32" drill bit along with a drill to clean and increase the four rivet holes marked in red.

Next, make a notch on both sides of the bed mount 1.25" from the bottom of the mount upward and 0.75" out from the inside edge where it contacts the frame.

**Note:** The RK117K front spring mount is positioned directly over a long bed mount and must be notched to make sure the new spring mount fits flat against the frame.

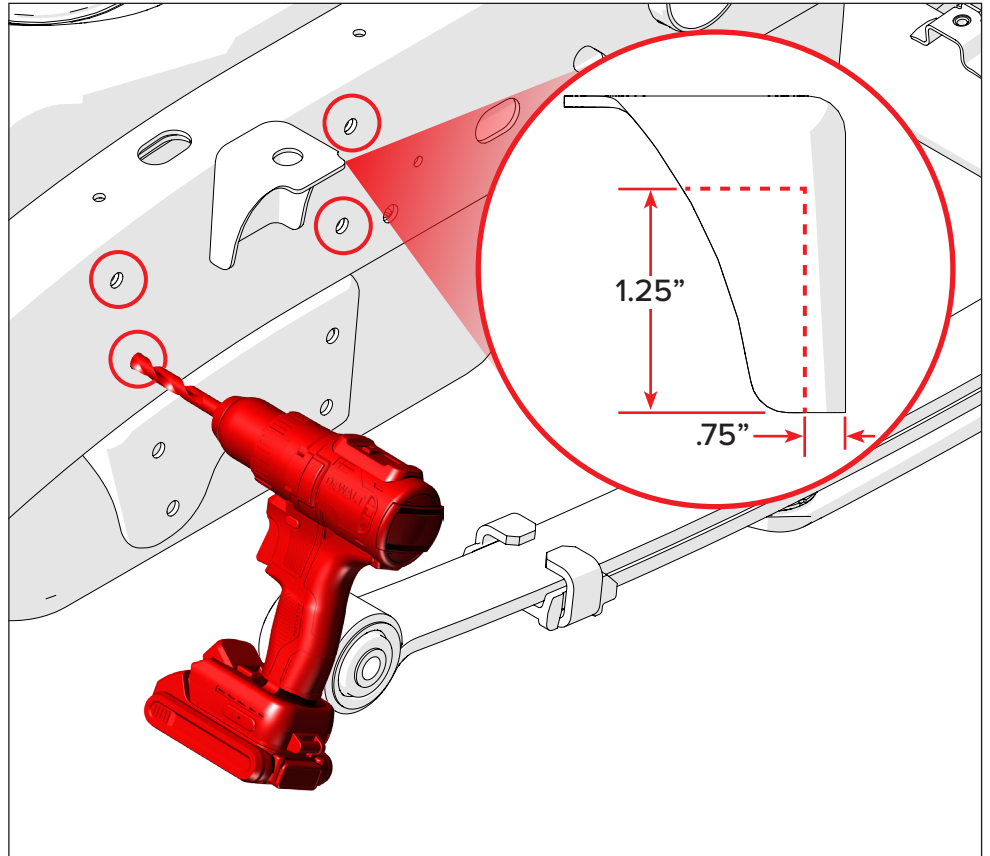

18

Attach the front spring mount (1) to the left side of the frame.

Use four bolts (15), eight flat washers (16), and four Nylock nuts (17).

Snug the fasteners for now, as they will be torqued to specification during step 20.

**Note:** Four of the flat washers and the Nylock nuts attach from the inner frame channel.

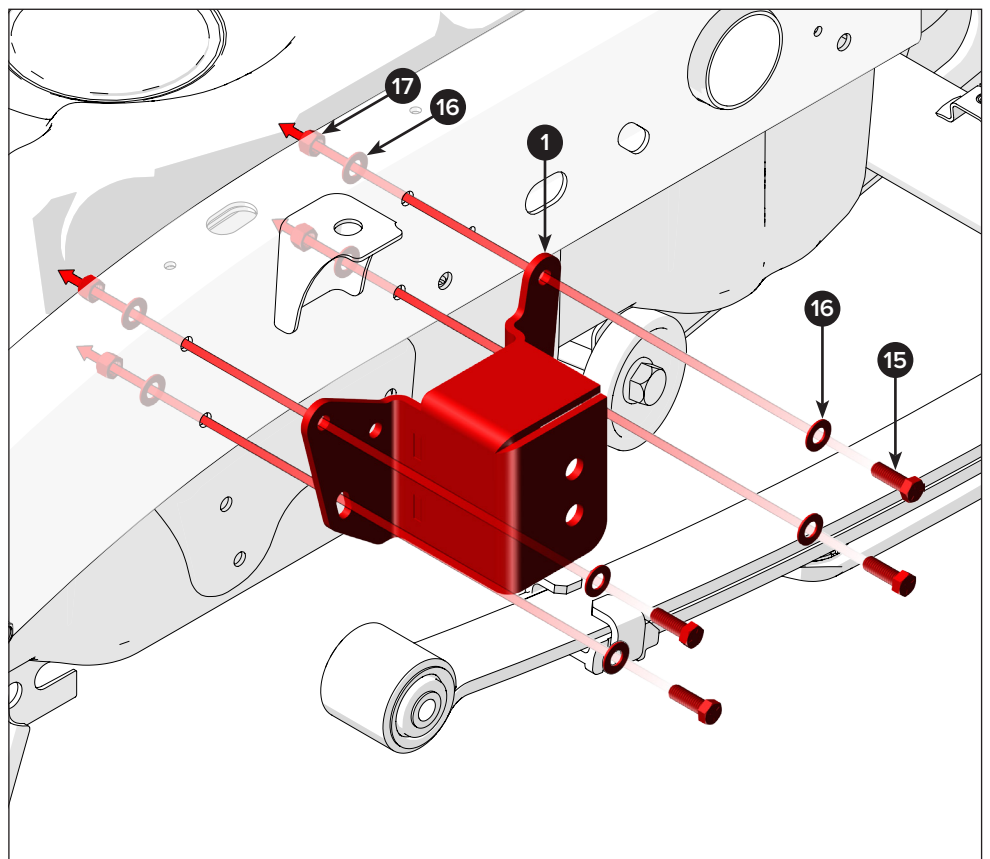

- 19** Drill through the fifth hole in the spring mount with the 15/32" bit.

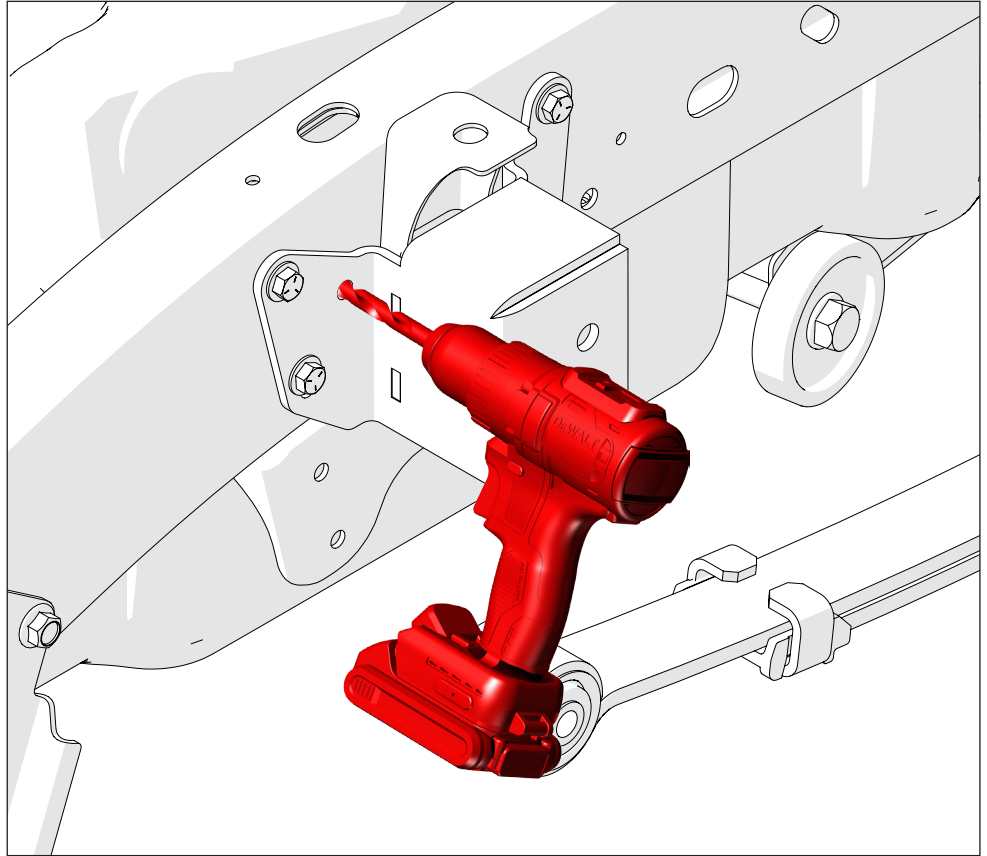

- 20** Use one bolt (15), two flat washers (16), and one Nylock nut (17) to complete the spring mount attachment.

Torque all front spring mount hardware to 49 lb-ft.

Repeat steps 18 through 20 to attach the right-side spring mount (2).

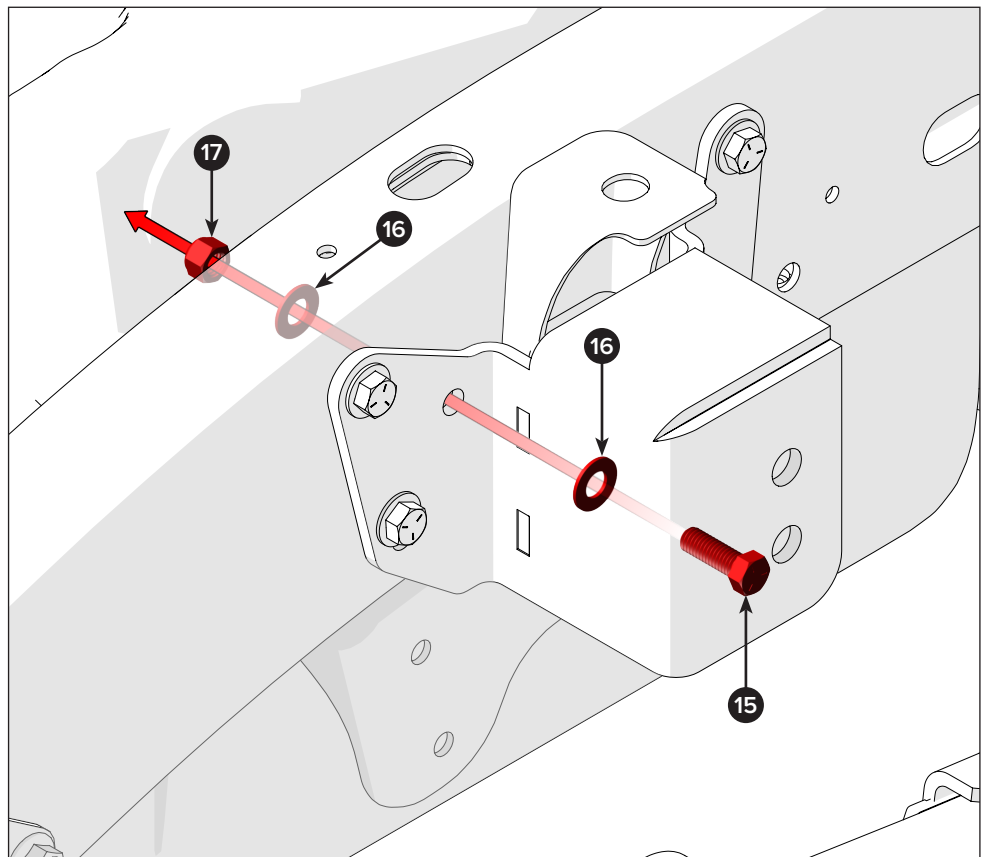

**Installer's Note:** The installation procedures from here to the end of these instructions are the same for short and long-bed trucks.

**21**

Remove the flange nut (K) from the top of the factory bump stop (L).

Discard the bump stop and nut. They will not be reused.

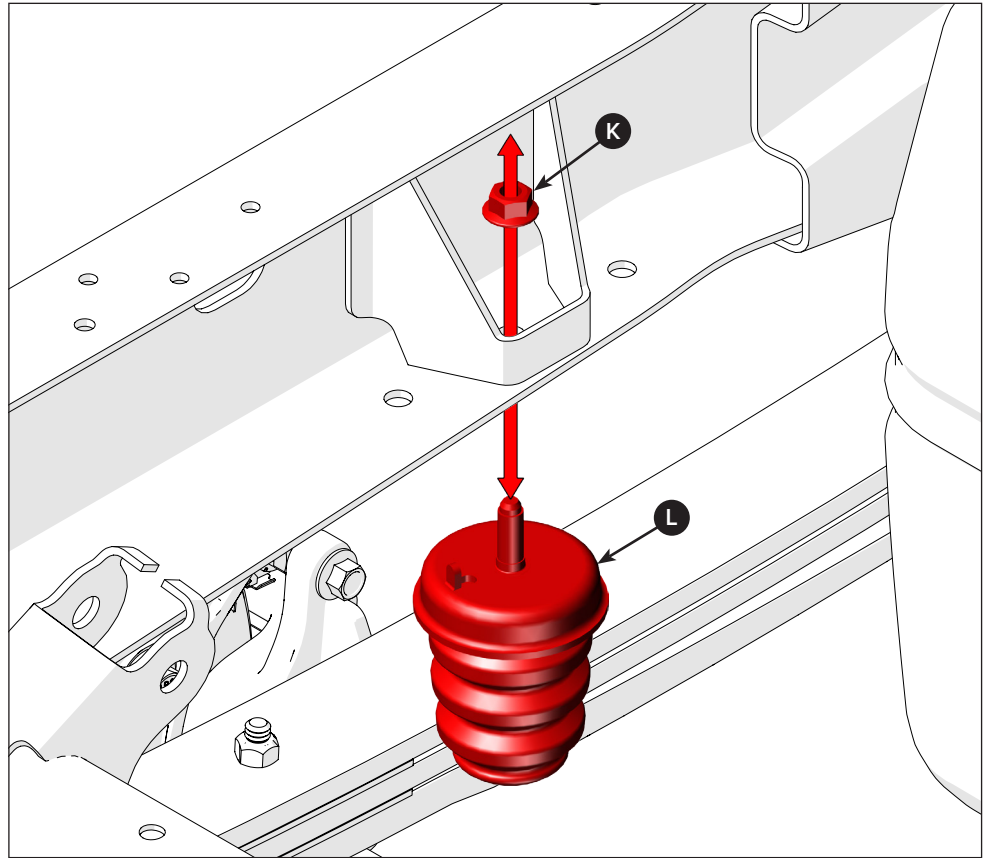
**22**

Install the new bump stop (8) to the bottom of the frame rail.

Use one flat washer (13) and one Nylock nut (14) to the bump stop threads.

Torque the nut to 10 lb-ft.

Repeat steps 21 and 22 to install the right-side bump stop.

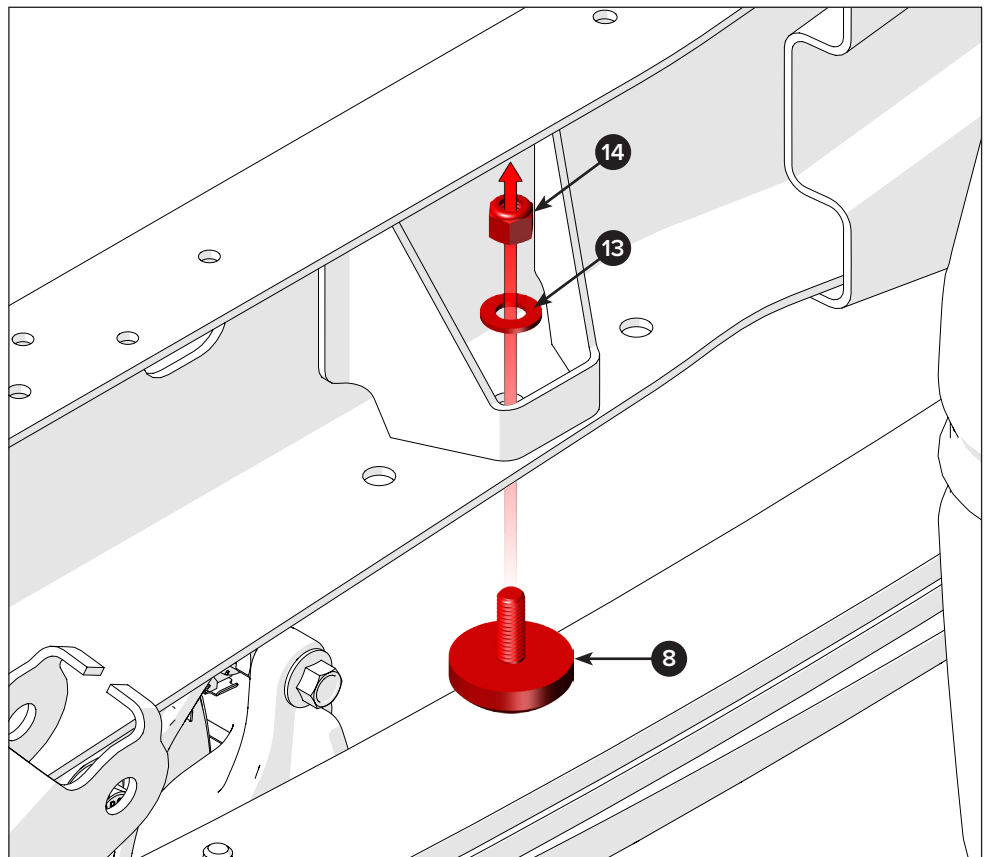

- 23** Raise the rear axle and leaf spring assemblies upward.  
 Make sure the rear spring eyelets are above the rear spring perch and the front eyelets sit inside the pockets of the front spring mounts.

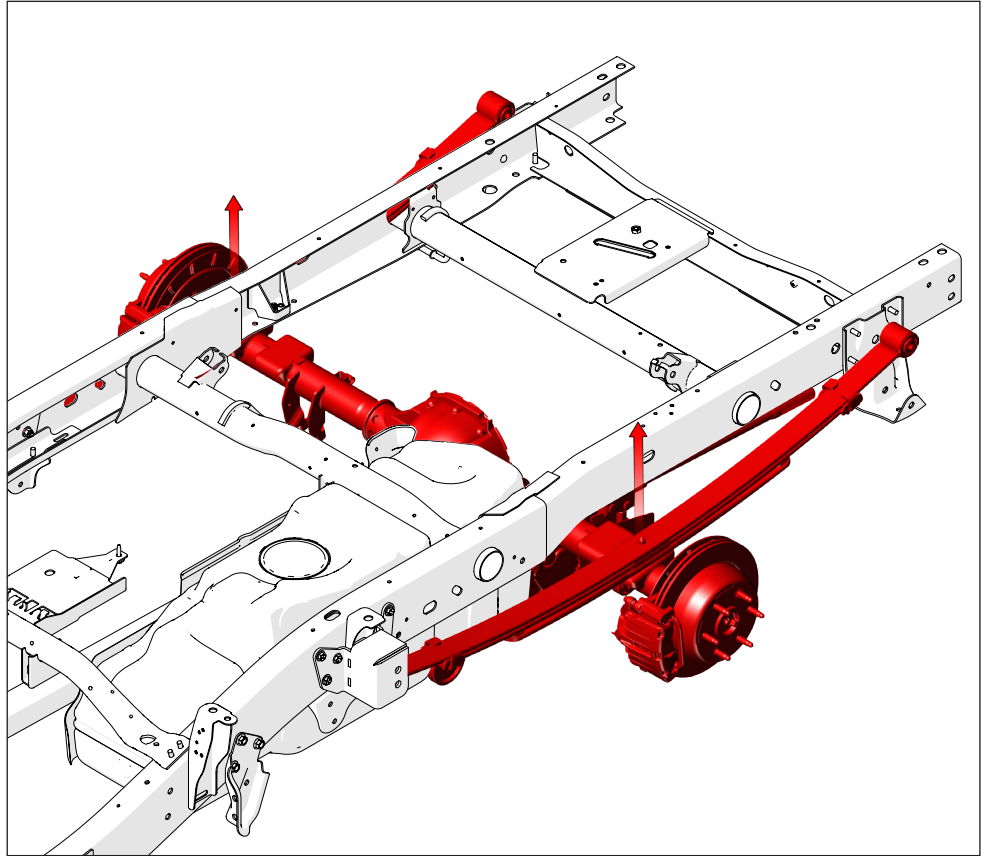

- 24** Adjust the axle height until the front spring eyelet aligns with the preferred bottom or top hole in the front spring mount.

Drop distance per hole:

**2.00" Drop:** Use bottom holes on front spring mount and rear spring shackle.

**3.00" Drop:** Use bottom holes on front spring mount and top holes on rear spring shackle.

**4.00" Drop:** Use top holes on front spring mount and rear spring shackle.

**Note:** The distance between the top and bottom mount holes is 1.50" and allows for a user-defined spring drop. Set to the desired ride height.

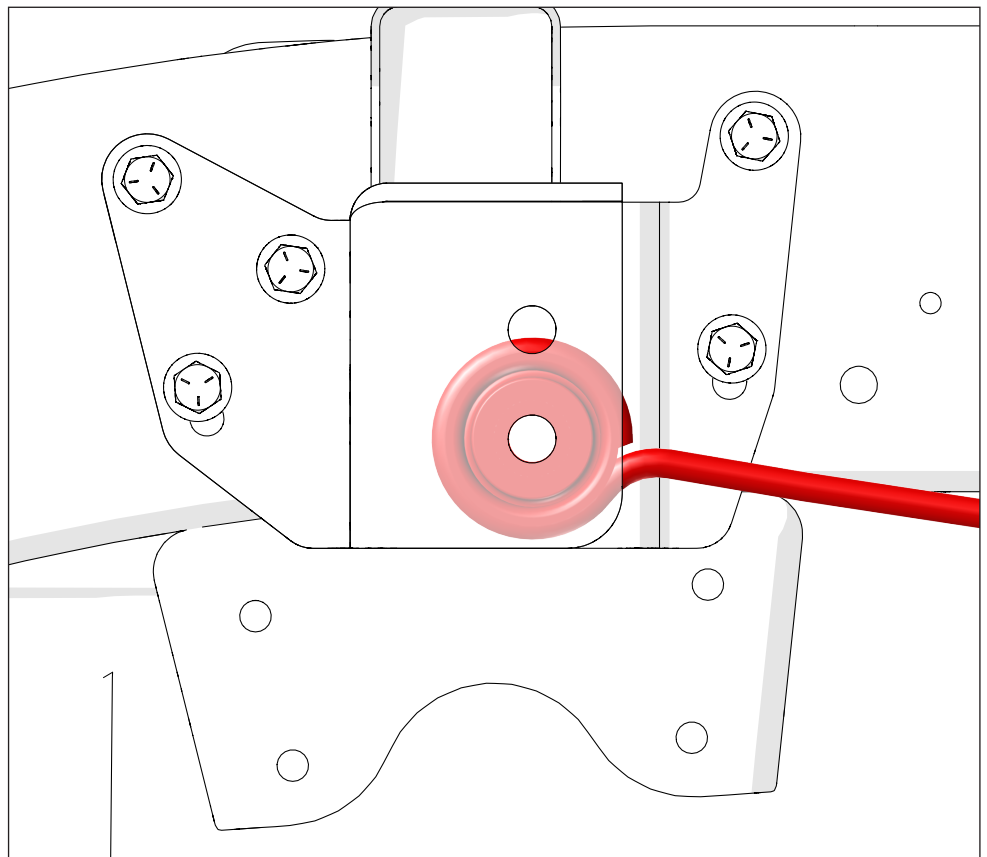

- 25** Insert one bolt (18) and one flat washer (19) through the chosen bolt hole in the front leaf spring mount.

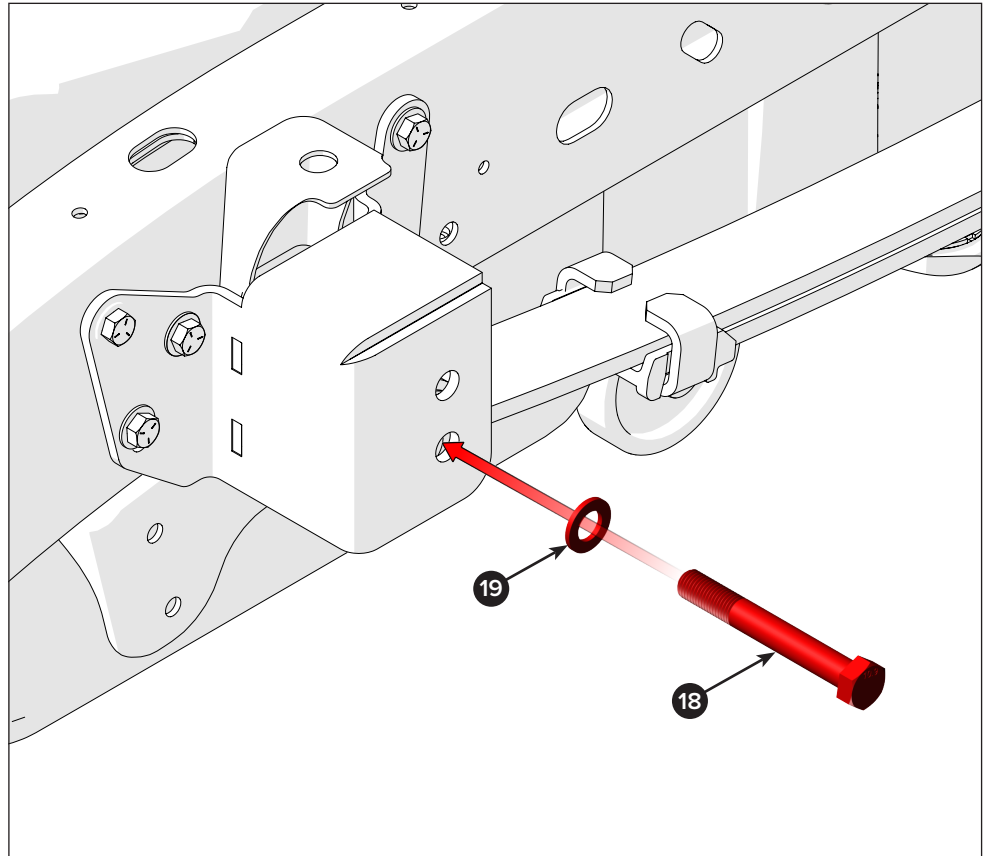

- 26** From under the frame, put one flat washer (19) and one Nylock nut (20) in the pocket behind the front spring mount.

Torque the fasteners to 110 lb-ft.

**Note:** The frame will prevent the use of a socket and ratchet. Use an open-end wrench to hold the nut in place.

Repeat steps 24-26 to attach the right side leaf spring to the right side front spring mount.

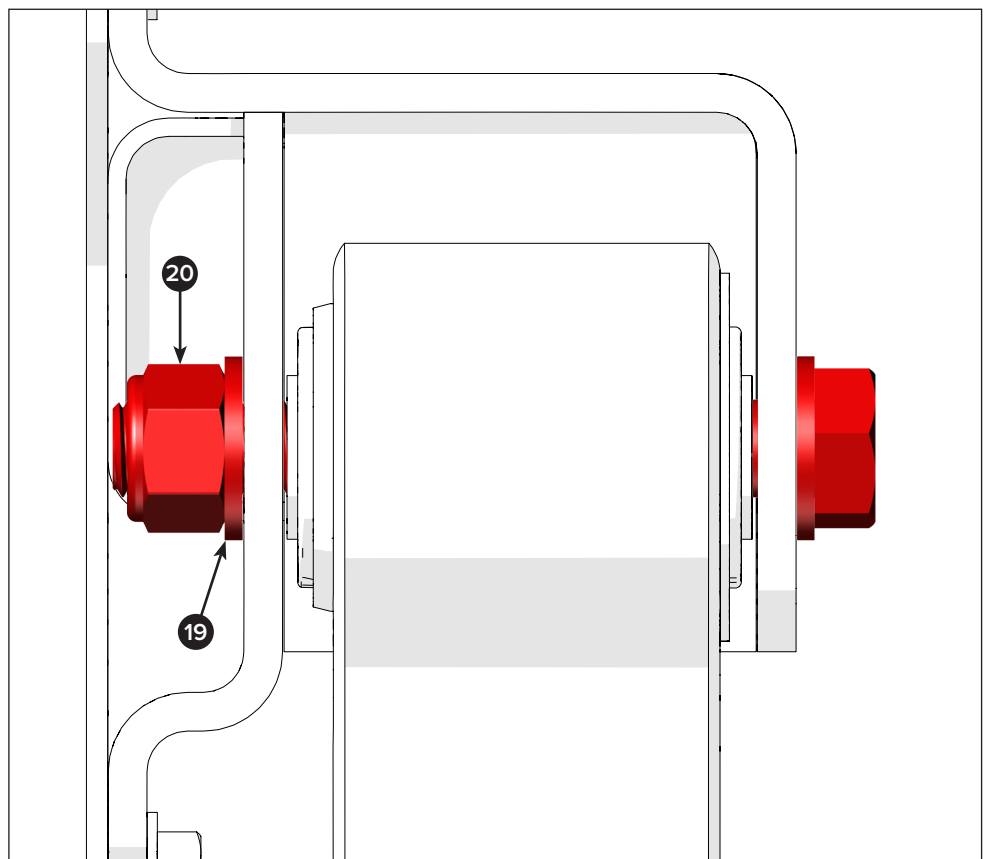

- 27** Put the rear leaf spring shackle (3) on to the rear leaf spring eyelet. Make sure the shackle bushings are on the bottom.

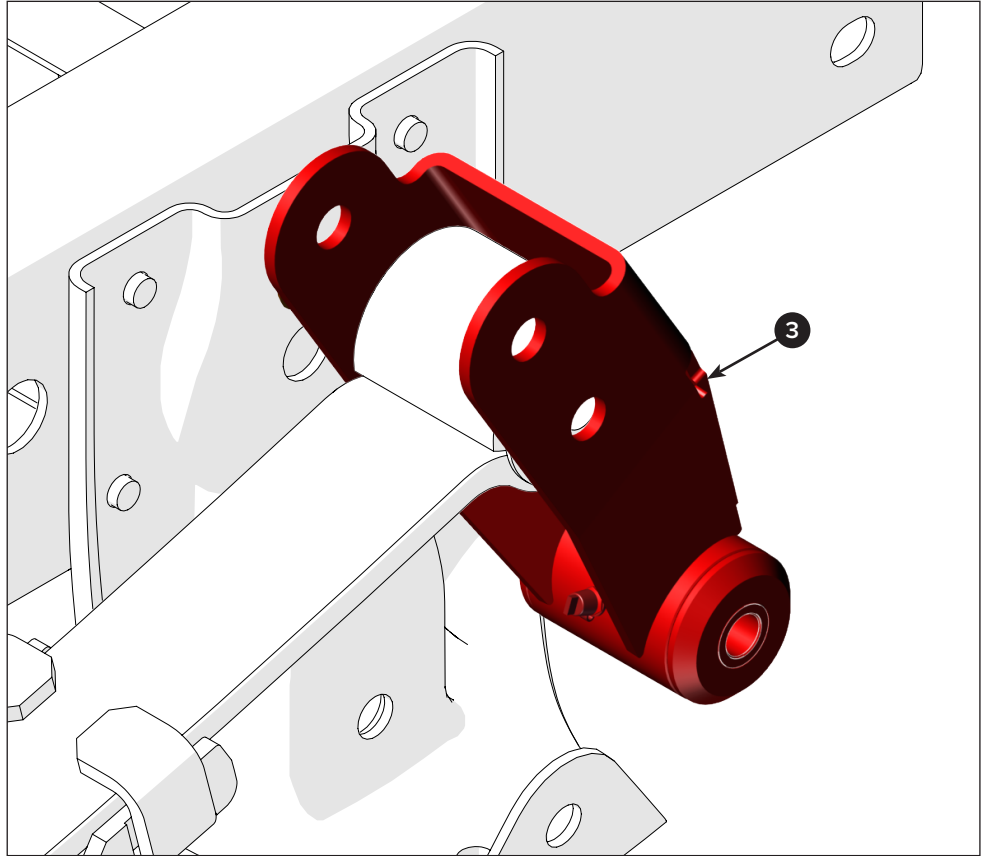

- 28** Put one bolt (10) and one oversized flat washer (21) through the shackle and spring eyelet.

Adjust the shackle height until the rear spring eyelet aligns with the preferred bottom or top hole in the rear spring shackle.

**Note:** The distance between the top and bottom mount holes is 1-15/16" and allows for an additional spring drop. Set to the desired ride height.

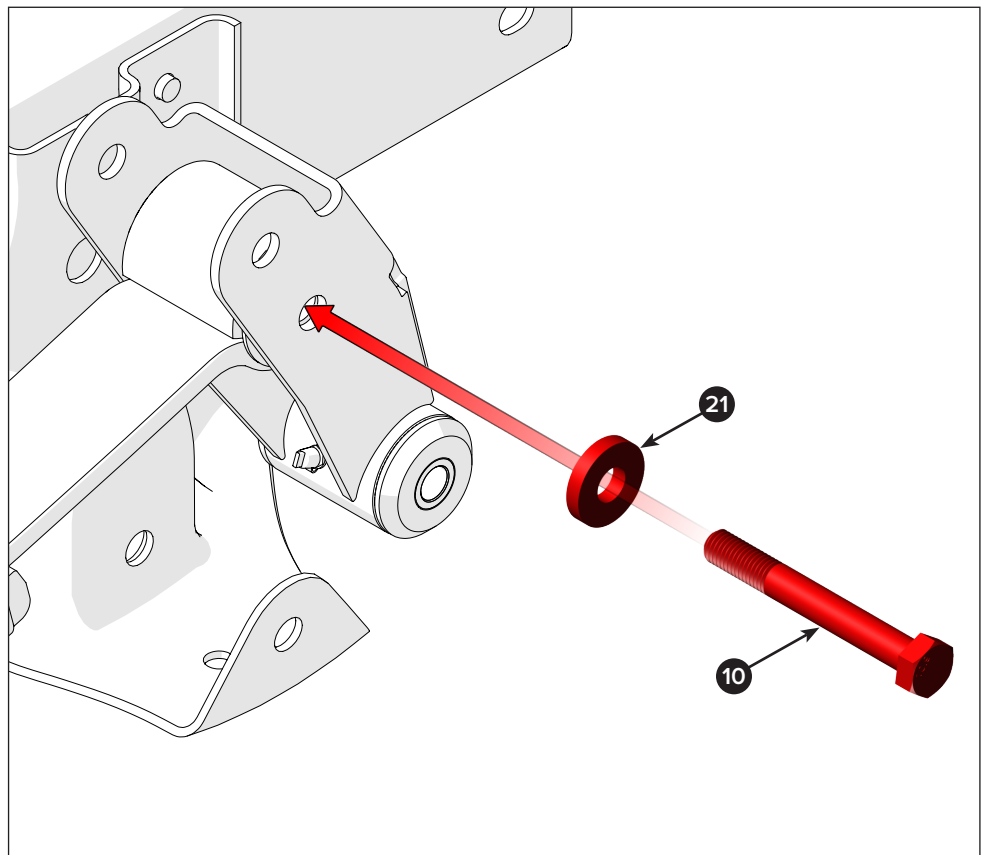

- 29** From above the frame, put one flat washer (11) and one Nylock nut (12) in the pocket behind the rear spring shackle.

Torque the fasteners to 70 lb-ft.

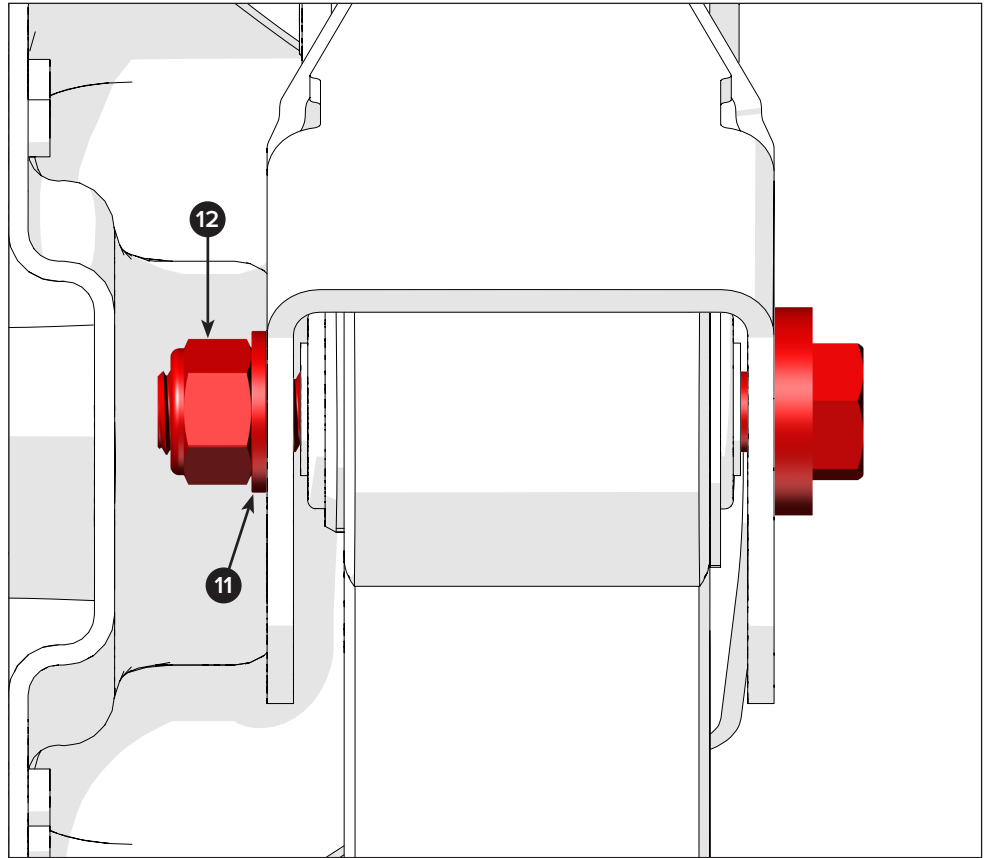

- 30** Put one bolt (10) and one flat washer (11) through the shackle and spring eyelet.

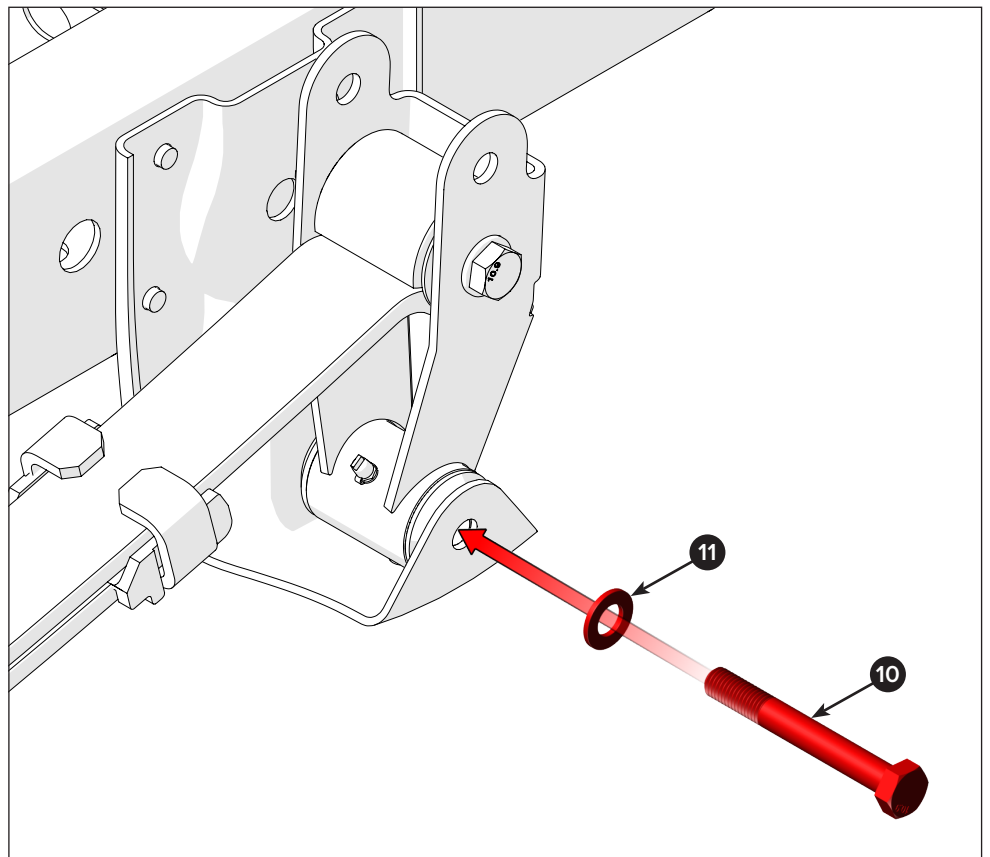

- 31** From below the frame, put one flat washer (11) and one Nylock nut (12) behind the rear spring shackle.

Torque the fasteners to 148 lb-ft.

Now you can install your chosen QA1 shocks that arrived with your drop kit. Refer to the installation guide included with the shocks.

**Note:** The installation guide can also be found online at QA1.

Go to [installation guide 9919-172](#) for the following shock systems:

- TS905 Single Adjustable Stocker Star Shock
- TD905 Double Adjustable Stocker Star Shock

To install the QA1 rear sway bar kit (PN 52880) on your Silverado/Sierra, refer to Installation Guide 9919-345, included with the sway bar kit.

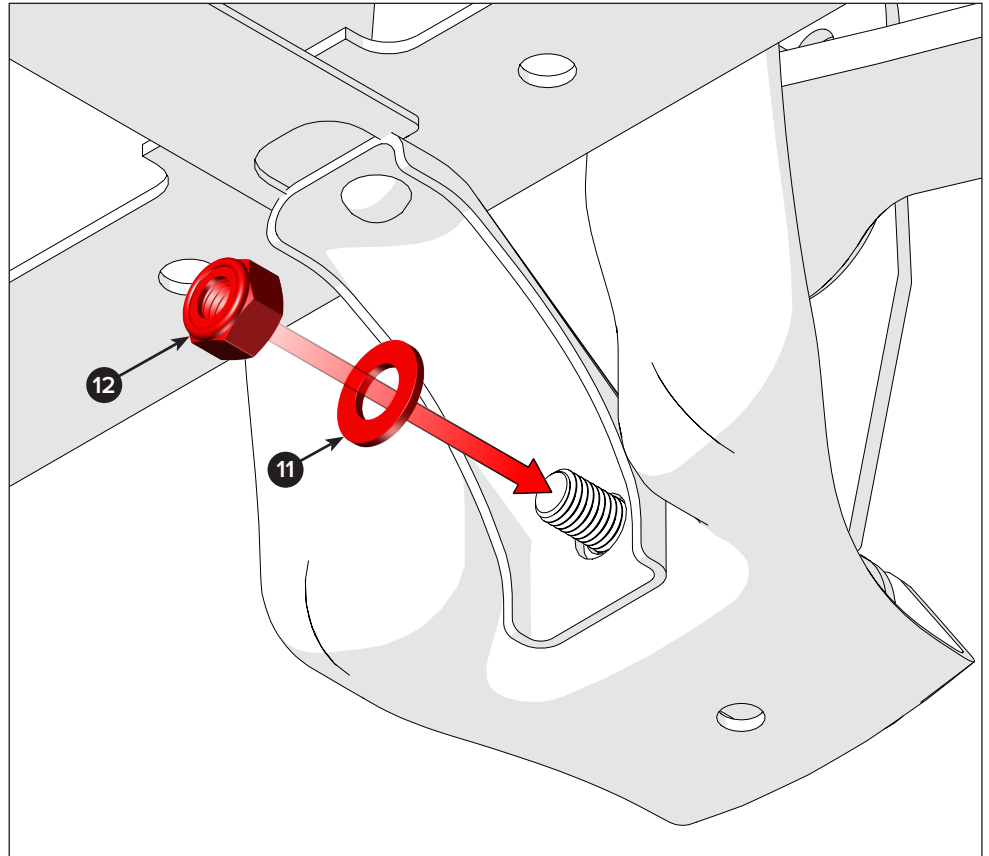

- 32** Place jack stands under the axle and lower the floor jack. Now cycle the suspension up and down to settle the leaf springs.

With the vehicle at the desired ride height, use an angle finder to measure the pinion and driveshaft angles to the transmission.

Make sure the pinion runs parallel to the engine and transmission.

In the top right image, the pinion is angled upward and requires adjustment.

The bottom right image illustrates the correct pinion angle.

Adjust the pinion angle at the axle pads with the included axle shims (9) if required.

If the pinion angle needs to be adjusted, refer to step 33 for installation instructions.

More information on pinion angles can be found at:

<https://qa1.net/resources/driveline-and-pinion-angle-explained/>

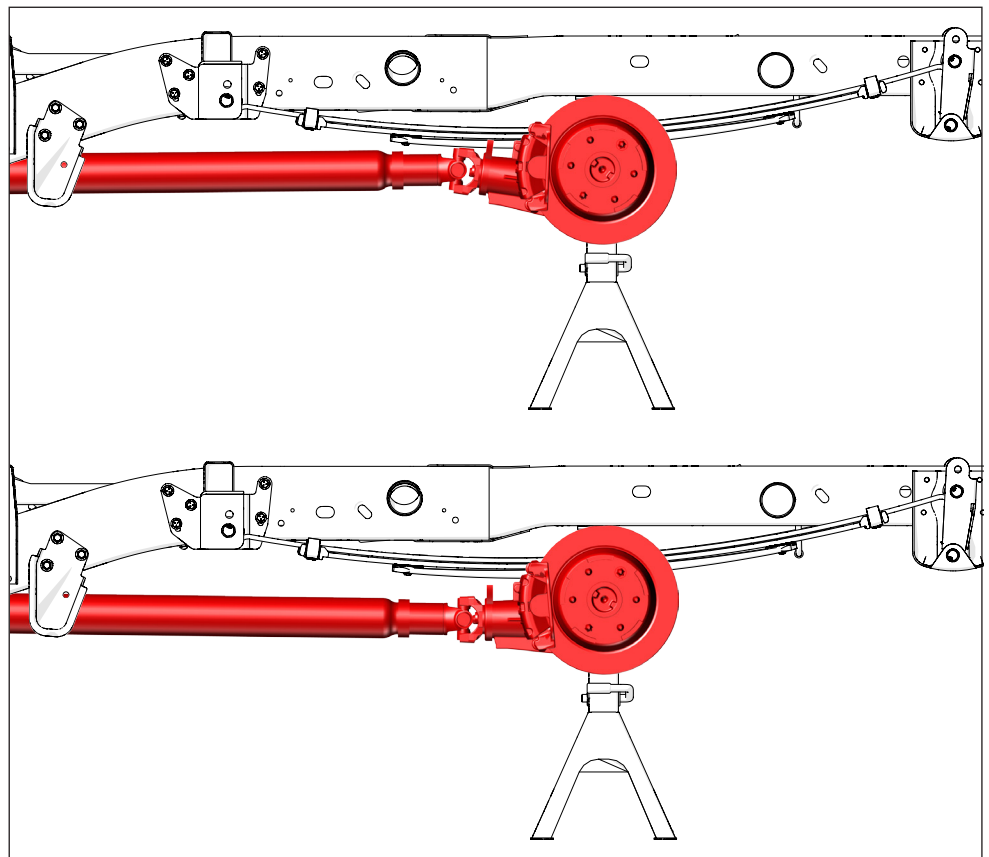

**Installer's Note:** If the leaf spring U-bolts and hardware are rusty, cut them off and replace them with new ones.

33

To add the shim, the axle must be separated from the leaf springs.

First, use a floor jack to lift the axle enough to remove the jack stands.

Then, remove the nuts and washers from the U-bolts. Set them aside safely if you plan to reuse them.

Lower the axle so the leaf springs separate from the spring mount pads on the axle.

The center pin on the leaf spring must clear the pad.

Slide a shim into place over the pinhole in the pad.

Point the thick end of the shim to the back (L) or the front (M) to raise or lower the pinion.

Install the shim on the right side of the axle and point it in the same direction as the left side.

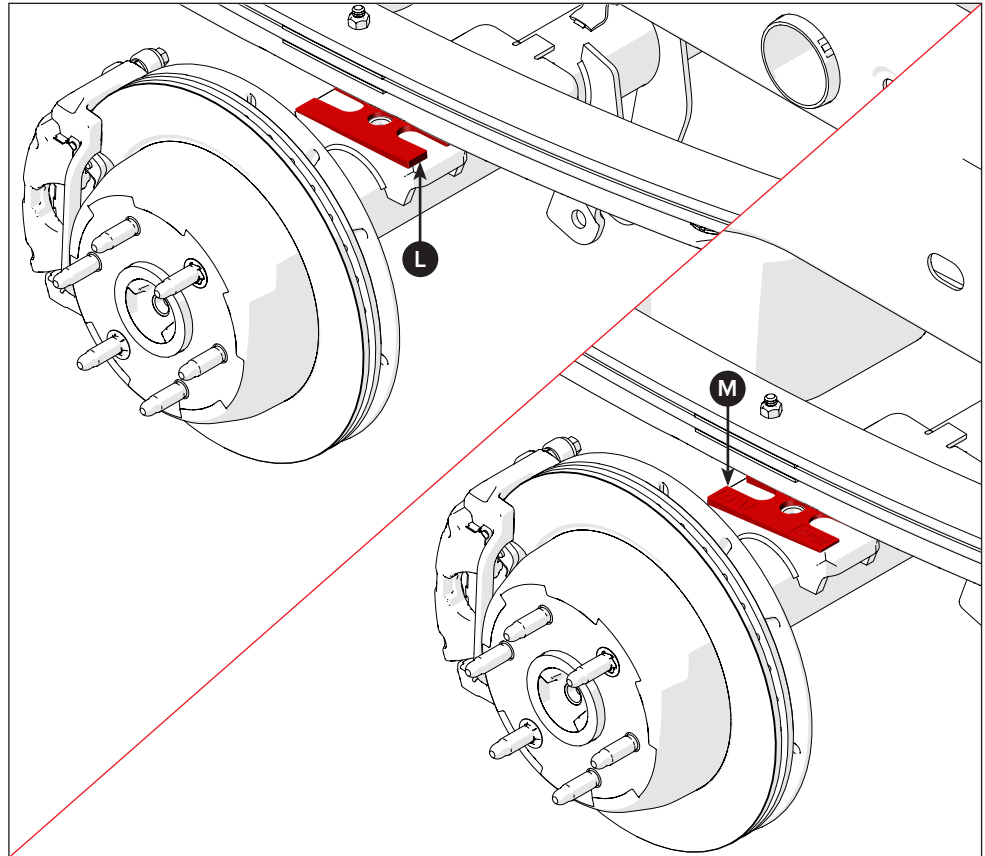

34

Now, raise the axle with the floor jack until it makes contact with the leaf springs on both sides of the vehicle.

Make sure the leaf spring's center pins seat into the shim and axle pad.

Reinstall the U-bolts into the bottom plate and fasten with the U-bolt washers and nuts.

Measure the pinion angle and make sure it is correctly aligned. If it is not correct, it will be necessary to purchase shims in the required angle degree.

**Note:** Do not stack shims! Multiple shims can slip out of position, cause loose U-bolts, and lead to dangerous driving conditions.

Once the correct pinion angle is achieved, install the lower mount plates, washers, and nuts (not shown).

Finally, torque the U-bolt nuts to specification.

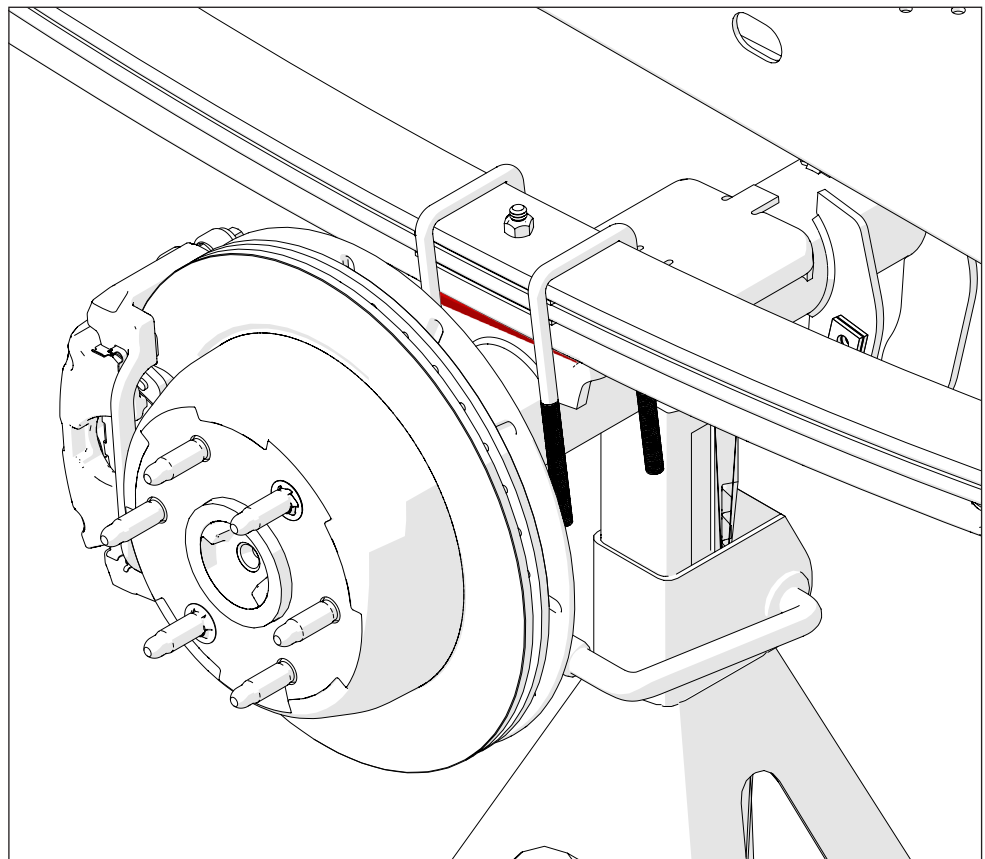

**DISCLAIMER / WARRANTY**

QA1 warrants the products to be free from defects in material and workmanship for one year from the date of sale to the original purchaser. QA1 makes no other warranty of any kind, expressed or implied.

QA1 shall have no obligation under the preceding warranty where the defect results from improper or abnormal use, your negligence, vehicle accident, inappropriate or incorrect installation or maintenance, nor when the product has been repaired or altered in any way. QA1's liability in the case of defective products subject to the preceding warranty shall be limited to the repair or replacement of the defective products at QA1's option.

The user understands and recognizes that racing parts, specialized street rod equipment, and all parts and services sold by QA1 are exposed to many varied conditions due to the manner in which they are installed and used. It is the user's responsibility to determine the proper use or application of QA1 products.

QA1 shall bear no liability for any loss, damage, or injury, either to a person or to property, resulting from the installation, direct or indirect use of any QA1 products, or inability by the buyer to determine proper use or application of QA1 products. With the exception of the limited liability warranty set forth above, QA1 shall not be liable for any claims, demands, injuries, damages, actions, or causes of action to the buyer arising out of or connected with using any QA1 products.

Motorsports are inherently risky; therefore, no representation or warranty is made as to the product's ability to protect the user from injury or death. The user is fully aware and assumes that risk.



